



Article

Patenting fashion: Salvatore Ferragamo between craftsmanship and industry



Carlo Marco Belfanti^{a,*}, Elisabetta Merlo^b

^a Dipartimento di Economia e Management, Università degli Studi di Brescia, Via S. Faustino 74B, 25122 Brescia, Italy

^b Dipartimento di Analisi delle Politiche e Management Pubblico, Università L. Bocconi, Via Roentgen 1, 20136 Milano, Italy

ARTICLE INFO

Article history:

Received 10 November 2014

Accepted 4 July 2015

Available online 26 September 2015

JEL classification:

N80

N70

Keywords:

Patent

Footwear industry

Fashion

Salvatore Ferragamo

Códigos JEL:

N80

N70

Palabras clave:

Patente

Sector del calzado

Moda

Salvatore Ferragamo

ABSTRACT

In the 20th century, a wide array of manufacturing activities related to fashion featured a long-lasting phase of continuous innovations both in production methods and ornamental designs. Among them, the Italian footwear industry stands out as one of the most recurrent entries in the databases of registered patents. Drawing on evidence collected from the American and Italian register of patents, the paper focuses on Salvatore Ferragamo with the aim of understanding the reason why he patented inventions and ornamental models, regarding both whole shoes and parts of them, with increasing regularity and what his attitude as an inventor tells us about product innovation in the footwear industry.

© 2015 Asociación Española de Historia Económica. Published by Elsevier España, S.L.U. All rights reserved.

Patentar la moda: Salvatore Ferragamo entre la artesanía y la industria

RESUMEN

En el siglo xx, una gran diversidad de actividades manufactureras relacionadas con la moda experimentó una fase perdurable de innovaciones continuas tanto en los métodos de producción como en los diseños ornamentales. Entre ellos, el sector italiano del calzado destacó como una de las contribuciones más recurrentes a la base de datos de las patentes registradas. Utilizando la evidencia recolectada de los registros de patentes de América e Italia, este artículo se centra en Salvatore Ferragamo a fin de comprender el motivo que le impulsó a patentar, con una regularidad creciente, inventos y modelos ornamentales tanto en relación con los zapatos como con las piezas que los componen, y entender lo que se desprende de su actitud como inventor en cuanto a innovación de producto en el sector del calzado.

© 2015 Asociación Española de Historia Económica. Publicado por Elsevier España, S.L.U. Todos los derechos reservados.

1. Introduction

Although extensive literature has been published concerning the history and economics of intellectual property, we still do not know a lot about the role played by patenting inventions and

ornamental designs for functional items in the 19th and 20th century development of the fashion industry. Indeed, couturiers and fashion designers have never been really interested in patenting their own inventions. The reason why they have regarded patenting as a worthless, if not potentially counterproductive, matter is twofold. Firstly, in the speedily changing world of fashion, a patent usually provides the inventors with a number of years of exclusive rights which often exceeds the life expectancy of fashion designs. And, perhaps most importantly, a design innovation requires, at

* Corresponding author.

E-mail address: marco.belfanti@unibs.it (C.M. Belfanti).

least to some extent, to be copied and imitated in order to turn itself from a promising idea into a profitable fashion trend.¹

Despite the fact that the rationale behind the fashion business does not conform to the rules of patenting, historical sources provide us with clear evidence that – with the Industrial Revolution first spreading from England to continental Europe and eventually to North America and, later, with the so-called American invasion of Europe – a wide array of manufacturing activities related to fashion featured a long-lasting phase of continuous innovations both in productive methods and ornamental designs. Among these, the footwear industry stands out as one of the most recurrent entries in the databases of registered patents, to the point that it has increasingly attracted the attention of scholars. As a result, a quite extensive literature about the relationship between patents, technological evolution, and innovations in footwear production, also covering different historical periods as well as national contexts, is now available to us (Church, 1970; Fontana et al., 1998; Le Bot and Perrin, 2012; Levitt, 1986; Segreto, 1989; Miranda, 2004; Miranda, 2009; Sabbatucci Severini, 2007; Thomson, 2010).

In terms of attitude towards innovation, the Italian footwear industry was no exception. Yet, the extent to which the founder of a fashion company that is still well known today – Salvatore Ferragamo – patented shoes in an impressive variety of models, systems of manufacture, and components appears to be rather atypical. Focusing on the ornamental designs patented by Salvatore Ferragamo between 1929 and 1960, our paper aims at investigating whether this kind of patents have had a role in laying the foundations of the development of the Italian fashion industry.

Historically, fashion industry and culture are rooted in well-defined urban or national milieus endowed with specific reputation and local identities. Although emanating from a long-standing tradition in textile and accessory manufacturing, the emergence of the Italian fashion industry dates back to the beginning of the 1950s, at the height of Ferragamo's creative activity. Furthermore, it occurred in Florence, the Renaissance capital, which he had chosen as the location of his headquarters. Perhaps a matter of a mere concurrence of events and circumstances without any apparent connection, yet such coincidences led us firstly to think of patents as an indicator of a sort of 'specialization in invention' unequally distributed in time and space (Sutthiphisal, 2006) and, secondly, to concentrate our investigation on the factors that might lead to a relation between the effervescence in patenting ornamental designs and the rise of Italian fashion to international standing.

This approach to the study of patents can be better understood in the light of some basic remarks about them as an exemplar of the role played by institutions in shaping the paths of technological change and in fostering economic growth. A patent gives inventors the right to stop anyone else from copying, using, distributing or selling the invention without their permission. Patents provide rewards and protection for inventors but they also benefit society. In return for patent protection inventors are expected to reveal the technical details of how their inventions work in their patent applications, so that anyone with basic knowledge of the invention's field can learn from them. In this way, patents help to spread new knowledge. However, what people learn from patents as well as how the information made available by them is used also depends upon the kind of idea – invention or ornamental design of functional items – patented. Usually, inventions are strictly related to advances in science and technology. In its turn, an ornamental design of functional items can be more easily taken as model of inspirations to be imitated, reproduced, and

even pirated. Furthermore, the specific characteristics of national legal systems can be the origin of different paths of diffusion of the knowledge arising from benefits of industrial property rights. In any case, despite the agreement of historians on the virtues of patents, the mechanism through which, as well as the extent to which, they have fed the process of innovation concerning low-tech industries is still largely unknown. In effect an ample corpus of literature exists regarding the role of patents as an institutional form of protection for IPRs and the propensity to innovation in industrial systems, above all with regard to process innovation (Scherer, 1965; Schmookler, 1966; Freeman, 1974; Rosenberg and Mowery, 1998; Giannetti, 1998; Sáiz González, 1999; Khan, 2005). Instead there is a lack of case studies that analyze the strategies that led to patenting product innovations in sectors that were subject to rapid cycles of renewal of the product itself as was the case in fashion. According to Raustiala and Springman "Patents are also hard to obtain. The application is expensive, the waiting period lengthy, and the prospects of ultimately gaining protection uncertain (...) Given the one or two season life of many fashion designs, design patents are simply too slow and unpredictable to be practical" (2012, p. 28). The study of the Ferragamo case allows us to delve into this paradox and can give economic and fashion historians new insights into the dawn of the Italian fashion business.

The paper will be organized as follows. The first part provides an overview of the history of the footwear industry between the 19th and 20th centuries. The second part focuses on the analysis of the main characteristics of the Italian legal system concerning industrial property and summarizes the main evidence provided by the database, collecting the inventions and ornamental designs relating to clothing, footwear, and accessories, which were registered at the Italian patent office during almost a century stating from the mid-1860s. The third part narrows the focus to Ferragamo's creative activity. A career inventor, he will be profiled both through the patents he registered in Italy and in the U.S. and by comparing them to the inventions patented by the American shoemaker Delmann, who was a contemporary of his. Part four contains some conclusive remarks concerning the contribution given by the Ferragamo case to our understanding of the foundation of the Italian fashion business.

2. The footwear industry between 19th and 20th century: an overview

The numerous efficacious, in-depth studies on footwear production in the Industrial Age have shown the process that led the production sector for these consumer goods to take on the physiognomy of a modern industry, in the form of factory systems that are able to satisfy a mass market. Between the 19th and 20th centuries, the production of footwear was involved in a series of technological innovations that transformed what had once been manufacturing traditionally based on the work of craftsmen into a modern industry. The process of change was differentiated both by mode and time period, according to the countries involved, but began in the United States, where the adoption of new technologies was established early, to then spread out into the European economies starting in Great Britain. In the United States, the manufacturing pole in footwear had already begun to be consolidated in the course of the 1850s in New England, where the technological innovations introduced into the sewing process were adopted into the making of shoes, starting the sector off towards progressive, increasing mechanization within the factory system, which took the place of traditional organization based on the putting-out system. This trend did not come to an end during the Civil War era, but was, instead, strengthened and accelerated by orders for military supplies (Thomson, 2010).

¹ According to Lydie Chantrell (1978), "counterfeiting started at the same time as haute couture, at the very moment when Worth began confecting a series of model destined for exportation" (quoted in Stewart, 2005, p. 108).

In the decades following the Civil War, the footwear industry underwent extraordinary development, fed in great part by the continuous flow of process innovations that radically transformed the production process (Thomson, 1991), inaugurating the age of mass production of shoes, absorbed initially by the internal market, but rapidly able to gain a share of the international market (Miranda, 2004; Miranda, 2009). In Europe the footwear industry remained tied to traditional forms of organization and to technologies that had mostly been established in the 19th century. In the United Kingdom, whose production occupied a primary position in the international market around the middle of the century, the footwear sector was made up of a nucleus of businesses with a workforce of a few hundred workers each, the majority of whom worked from home. In the following two decades, British manufacturing underwent a first important cycle of transformation, driven by the introduction of the American technology, which became decisive in the second phase of development between the end of the century and the First World War (Church, 1968; Church, 1970). In Germany too, the years preceding the Great War were marked by the start of a process of modernization in the footwear sector sustained by the introduction of machinery imported from the United States (Miranda, 2009, p. 4). In Switzerland, a great company, whose organization was inspired by the American model, was active: with nine factories and 4000 employees; Bally was the most important European shoemaker at the beginning of the 20th century (Miranda, 2009, p. 4). The other countries on the Continent had more fragmentary setups. In France, only a handful of small businesses were active and the production processes were out of date – with the single, partial exception of the André group – but the *haut de gamme* articles enjoyed a good reputation in the international market (Le Bot, 2005; Miranda, 2009; Le Bot and Perrin, 2012). Likewise, the quality of the product also guaranteed Austrian manufacture of shoes good distribution on the international market (Miranda, 2009, p. 5). Spanish footwear production did not have the characteristics of a modern industry and was above all sustained by exports towards the colonial markets (Miranda, 2009, p. 5). In Italy, there were a few manufacturers with mechanized production systems in the North-West of the country, but the majority of the production came out of small workshops that created hand-made items (Segreto, 1989; Fontana et al., 1998; Bravo and Merlo, 2002; Sabbatucci Severini, 2007).

The First World War constitutes an important watershed in the history of the footwear industry because the stimulus produced by military supply orders accelerated the pace of modernization of the production process in the majority of European states. The increasingly fierce competition, determined by a major number of producers, on the one hand and the economic crisis of the Thirties, with the consequent contraction of consumption and protectionist policies on the other hand, redesigned the structure of the shoe-making industry in Europe. The sector was dominated by medium-to large-size businesses, characterized by a notable territorial concentration – as happened in Great Britain, Germany, Switzerland, Czechoslovakia and Italy – some of which also controlled the sales channels (Miranda, 2009, p. 6–10). It was in this context that the business founded by Thomas Bata in Moravia emerged as one of the protagonists, rapidly establishing itself as a multinational business, active in diverse countries, and aiming at the production of standardized articles at low cost (Le Bot, 2005; Miranda, 2009).

Historiography converges in identifying the American machines and their adoption in production systems based on factories as the key factor in the development of the modern footwear industry between the 19th and the 20th centuries, although many European manufacturers could also exploit the advantage of the low cost of the work. In such a context, competition was therefore based essentially on the price and on production on a vast scale, while quality characteristics and design seem to have played only a marginal role;

the decisive innovation was innovation in the production process and not innovation in the product itself. The studies available do not exclude, however, that in some contexts and in some circumstances the components of quality could have taken on a relevance which should not be overlooked. The possibility of depositing and registering models and designs with the aim of protecting and furthering product innovations was available in the U.K. at least from 1839 (Levitt, 1986, p. 1–5). Amongst the firms that used these instruments was for example that of Cyrus and James Clark who registered the model of the “Osborne boot” (1856), or Jesse Harrison who deposited the model of a machine-sewn boot that “equals in appearance any hand sewn boot, combining lightness and durability of wear at a great reduction in cost of production and is especially adapted for evening parties, dancing or walking” (Levitt, 1986, pp. 156–157). This early – but probably not so widespread – sensitivity towards product innovation in the footwear sector was not however sufficient to protect the British industry from the American competition, whose articles, while less long-lasting, were “more comfortable, lighter in weight, and more stylish than that worn by the British middle classes prior to 1890” (Church, 1968, p. 251). However, such sensitivity was a sign that attributes different from those of being robust and long-lasting were becoming crucial to the quality of the product.

Primacy in *Haute Couture* perhaps underlay the French specialization in quality shoemaking that incorporated the added value of fashion trends and which found a warm welcome in the international market (Miranda, 2009, pp. 4–5). Up to the First World War, shoes produced in Austria too, were, as has already been said, characterized by a high level of quality, probably connected to aspects of design (Miranda, 2009, p. 5).

In the Italian industry, attention to innovation in the product had already shown itself in the period between the two World Wars; an important Italian manufacturer, Voltan, patented the model for the “Solleva” shoe in 1939, a shoe which was distinct in its use of particular materials for higher comfort (Fontana et al., 1998, pp. 114–115). It was only however after the Second World War that the Italian shoe manufacture established itself on the international market due to its superior quality, as well as its competitive price (Segreto, 1989; Miranda, 2009, pp. 12–13).

However, despite the fact that the academic literature has clearly outlined the evolutionary path of the shoemaking industry, illustrating the transformations in the production process that led to the establishment of countries and companies that imposed themselves on the international market, the role played by innovation in the product and more particularly by design and fashion as elements in the quality connotation of the product remains still largely unexplored.

Patents are a means to address the issue.

3. Industrial property in the Italian legal system: facts and figures

The records of the patents registered in Italy from 1864 to the end of 1960s are kept by the Central State Archives. They are organized in three series: inventions, models, and trademarks. The first series is the largest and oldest. It contains approximately 620,200 files covering the period 1855–1962 and spanning almost all the various economic activities. The second series includes useful and ornamental models and collects about 100,000 files from 1876 to 1965. The official classification clearly distinguishes useful from ornamental models (Ministero dell'industria del commercio e dell'artigianato, 2000). The former is “a discovery that results in machinery or parts thereof, instruments, utensils or objects which feature a remarkable effectiveness in terms of practicality of use or

application". The latter is a "form, or combination of lines, colours, or other decorative elements which makes an industrial product clearly distinguishable". The third series contains 171,000 trademarks concerning the period 1869–1965 (Martelli, 2011).

The Central State Archives received the records from the Italian Patent and Trademark Office. Its origin dates back to 1861, the year the "Ufficio delle privative industriali dei brevetti e dei marchi" was established under the control of the Ministry of Agriculture, Industry, and Commerce. In 1862, it was annexed to the Industrial Museum in Turin, at that time the capital of the Kingdom of Italy. In 1884, it was transferred to Rome, becoming a part of the Industry and Commerce Division of the Ministry. It was not until 1923 that royal decree n. 1970 regulated its functions, stating that it was a special office managed by the Ministry of Industry and Commerce with the aim of providing services related to patents of drawings and models, trademarks and distinctive signs of manufacturing and national and international commerce. The following decade marked a turning point for the protection of industrial property in Italy. The Convention for the Protection of Industrial Property signed in Paris in 1883 was acknowledged with a bill approved in 1934 and made law in 1939 (royal decrees n. 1602 and 319 respectively). According to jurists (Franceschelli, 2003), at that point Italy fully entered into modern industrial property law. The substantive provisions of the Convention, which is still today in force, fall into three main categories: national treatment, right of priority, and common rules.² They all aim at reciprocally enforcing and promoting the widest circulation of knowledge.

According to the information provided by our database, embracing the spirit of the Paris Convention seems to have had an immediate impact on patenting items and designs related to fashion, as broadly conceived. They more than doubled between 1937 (73) and 1938 (193) before decreasing to 145 in 1940 and then returning to equal the mid-1930s level between 1943 and 1946. After World War II, the number of inventions and ornamental designs filed yearly only occasionally fell below the average of the pre-war period (Fig. 1).

The database collects patents concerning footwear, clothing, accessories, hats and caps, underwear, and knitting. As Fig. 2 shows, the footwear category has made a substantial contribution to the overall number of patents. Since the 1950s, it has more than doubled the number compared to the categories of accessories and clothing, which respectively rank second and third.

Such dynamism allows us to consider patents related to footwear as a reasonable proxy for patents broadly related to fashion. Consequently, our findings on this specific category can be applied, to some extent, to the fashion sector as a whole. This is particularly true for what concerns inventors. Along with ideas individually patented by inventors who are completely unknown today, the footwear category includes a large number of inventions patented by firms representative of well-known Italian industrial clusters, amongst which we may mention the footwear district of Vigevano (Pavia); small company towns such as Varese, Parabiago, and Tradate; and Porto Sant'Elpidio, which still today hosts the

headquarters and plants of the Tod's Group. The database, to sum up, seems to suggest that, to some extent, industrialization and sectorial specialization have been sourced from patenting inventiveness.

While not an exception within the category of shoemaker patentees (Lupano and Vaccari, 2009), Salvatore Ferragamo yet surely stands out as the most prolific inventor at the time.

4. Salvatore Ferragamo, a career inventor

One of the 14 children, Salvatore Ferragamo was born in Bonito, near Naples, in 1898 (Ferragamo, 1985). He began an apprenticeship with a Naples shoemaker at the age of 11. In 1912 he set out to join his older brothers who had travelled to the United States in the preceding years. At first he went to Boston, where one of them worked for a large shoe manufacturer using industrialized shoemaking techniques. After nearly a decade, at the beginning of the 1920s, he decided to move closer to one of his other brothers, who lived in Santa Barbara, California. There, Ferragamo opened his own shoe shop using traditional shoemaking techniques and soon began to work for the film industry as a designer and maker of shoes. The quality of Ferragamo costume shoes led actresses and actors to ask him to make them footwear for off-screen wear as well, and Ferragamo quickly established a reputation among people in the movie business. In order to be in closer proximity to his new clientele, he moved to Hollywood where he opened his own shop in 1923.

Ferragamo's fame as a shoe designer rose steadily in the 1920s and his customer base spread beyond the acting world and beyond his capacity to complete the orders he received. The attempt to expand his shop into a larger shoemaking business failed, given the lack of qualified personnel in the United States, thus forcing him to return to Italy.

In 1927, Ferragamo set up a new business in Florence, a primary centre for the Italian shoe industry at the time. We can suppose that he was attracted there because the supply of trained workers was plentiful. Moreover, evidence of the interest of the USA in Italian handicraft was offered by the buying organizations maintained in Italy – and established precisely in Florence – to supply the large and growing demand in America (Marcucci, 2004).

Following the crisis of 1929, orders from the United States, which until then had continued to be the main market for Ferragamo's shoes, collapsed. Faced with re-building his business after it went bankrupt in 1930, he focused on the domestic market and began to establish his name as a pre-eminent Italian shoe manufacturer. His inspired designs and quality craftsmanship quickly brought him a growing customer base, to the point that by the mid-1930s Ferragamo was operating two workshops. In 1936, he also opened a shop in the 13th century Palazzo Spini Feroni which is still today the company's headquarters and houses the Salvatore Ferragamo Museum.

While remaining committed to traditional handcrafted shoemaking techniques, Ferragamo was able to adapt them to modern production methods by exploiting the knowledge of the disciplines – human anatomy and mathematics – he studied at Los Angeles University (Cohen, 2014).

A clear evidence of the influence exerted on Ferragamo's vocational training by such fields of knowledge can be found in his first American patent (Annual report of the Commissioner of Patents, 1921, p. 164), concerning the invention of "certain new and useful improvements in turnbuckles" (Fig. 3), later applied to the surgical appliances (Fig. 4) (Annual report of the Commissioner of Patents, 1921, p. 1072), the fracture apparatus setting and splint (Fig. 5), and the apparatus for supporting injured limbs (Fig. 6) (Annual report of the Commissioner of Patents, 1924, p. 194).

² Under the provisions on national treatment, the Convention provides that, as regard the protection of industrial property, each contracting country must grant the same protection to nationals of other contracting countries that it grants to its own nationals. Nationals of non-contracting countries are also entitled to national treatment under the Convention if they are domiciled or have a real and effective industrial or commercial establishment in a contracting country. The right of priority means that, on the basis of a regular first application filed in one of the contracting countries, the applicant may, within one year for patents and utility models and six months for industrial designs and marks, apply for protection in any of the other contracting countries. One of the great practical advantages of this provision is that applicants seeking protection in several countries are not required to present all of their applications at the same time but have a certain time to decide in which countries they wish to seek protection.

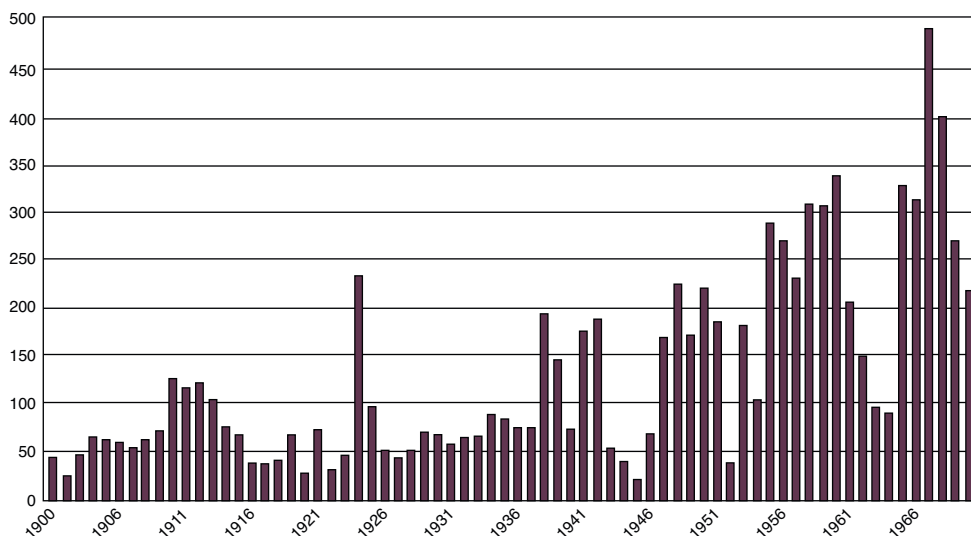

Fig. 1. Patents, 1900–1970. *Source:* Ministero di Agricoltura, Industria e Commercio, *Bollettino delle Privative Industriali del Regno d'Italia*; Ministero di Agricoltura, Industria e Commercio, *Bollettino della Proprietà Intellettuale*; Ufficio Centrale dei brevetti per invenzioni, modelli e marchi, *Bollettino dei brevetti per invenzioni, modelli e marchi*.

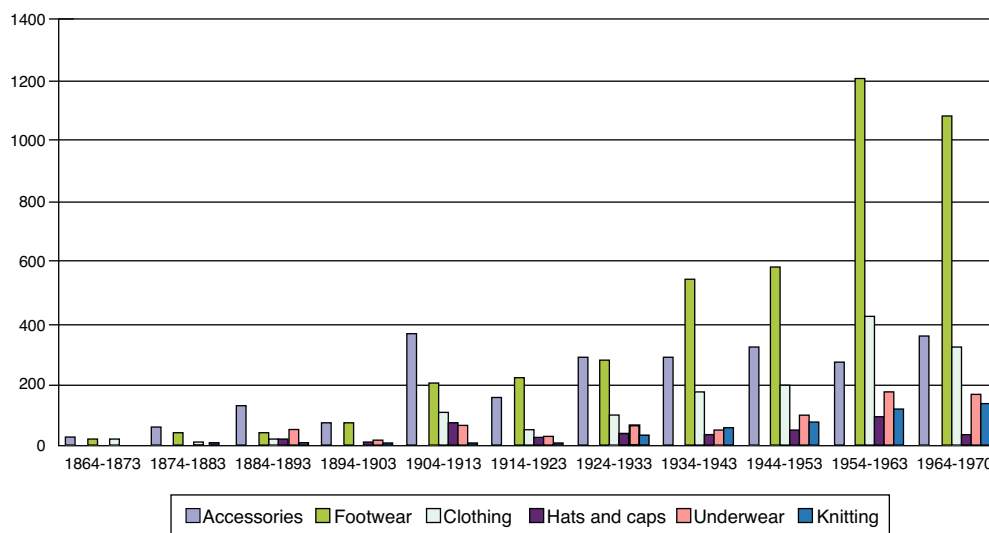

Fig. 2. Inventions patented by category, 1864–1970. *Source:* Ministero di Agricoltura, Industria e Commercio, *Bollettino Industriale del Regno d'Italia*; Ministero di Agricoltura, Industria e Commercio, *Bollettino delle Privative Industriali del Regno d'Italia*; Ministero di Agricoltura, Industria e Commercio, *Bollettino della Proprietà Intellettuale*; Ufficio Centrale dei brevetti per invenzioni, modelli e marchi, *Bollettino dei brevetti per invenzioni, modelli e marchi*.

Once back in Italy, Ferragamo began to patent shoes as well as parts of them. At first, he experimented new ideas in shoemaking by exploiting his knowledge of orthopaedics. This is the case of the patent – registered both in the U.S. and in Italy³ – for a stiffener for strengthening the soles of shoes (Fig. 7). According to the inventor, the need for such reinforcement “is especially felt in ladies light shoes where the pronouncedly high heels do not allow for the due support of the foot when the arch of the sole is not sufficiently rigid, while the need for an adequate connection between the heel and the sole is further felt, owing to the thinness of the sole in ladies’ shoes”.⁴ Then (1930s–1960s), he focused on improving and innovating shoes.

The research we have carried out within the American *Annual report of the Commissioner of Patents* has provided us with just a handful of designs patented by Ferragamo in the 1930s (Figs. 8–11) – compared to the almost one hundred patents he registered in Italy between 1929 and the end of the 1940s – which, with the exception of some details, are related to models very similar to those patented in Italy.

All of the above mentioned patents concern one of the most famous inventions by Salvatore Ferragamo: the wedge, patented in Italy in 1937,⁵ which is a lifted heel without a stiletto heel. The result is a shoe that is flat with respect to its base and to the surface on which it is posed. In 1938 *Vogue USA* credited Ferragamo with being “responsible for this radically new idea, the uplift of

³ The Italian patent is numbered 281241 and it was registered on January, 7 1931 (Ricci, 2004, p. 44).

⁴ Historical Archives of the United States Patent Office, Patent No. 1.862.359.

⁵ Patent No. 354889, 13 December 1937 (Ricci, 2004, p. 87).

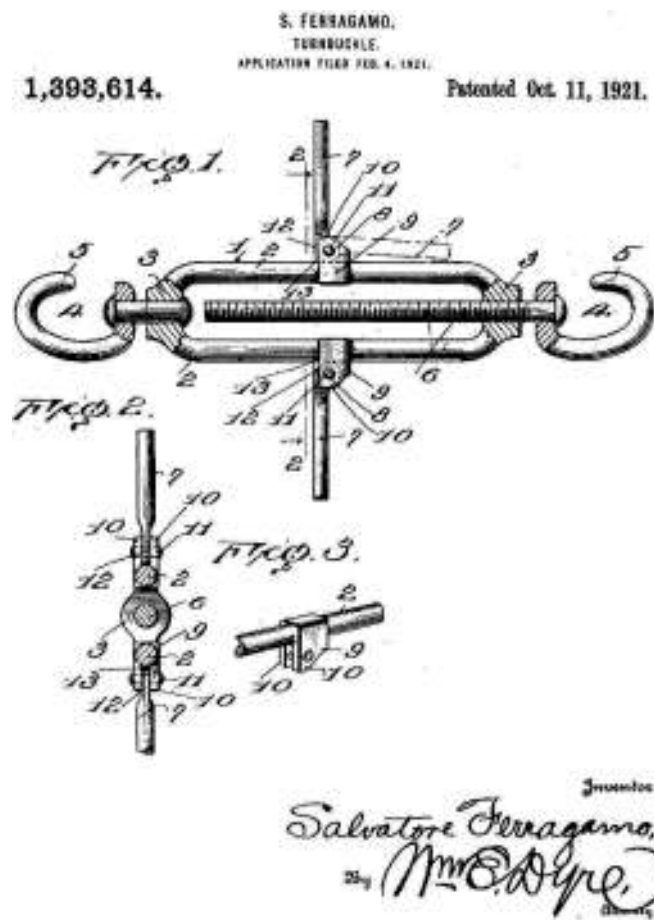

Fig. 3. Turnbuckle. Drawing, 1921. Source: Historical Archives of the United States Patent Office, Patent No. 1.393.614.

the sole".⁶ The first patent (Fig. 8) concerns the ghillie shoe,⁷ a type of shoe with laces along the instep and no tongue, similar to those used for Scottish country dancing. At the beginning of 1938 Vogue USA advertised for this model describing its "blue calf sole [which] ascends to a calf covered cork heel on a red suede ghillie". It was "produced for and imported by Saks-Fifth Avenue department store".⁸

Again in 1938, the "ghillie" shoe was advertised by Vogue along with three models of shoes designed by Ferragamo. The model of shoe reproduced in the second patent, a sandal (Fig. 9) was one of them. As far as the remaining two patents are concerned (Figs. 10–11), the first one features a sandal which differs from the model in Fig. 9 because of the lace, which starts from the sole, wraps the heel and the instep and is fastened to the opposite side without any means of fastening such as buckles or buttons⁹; the second concerns the application of the weaves and nets system, patented in Italy in 1938,¹⁰ to the wedge to form shoe uppers.

According to the authoritative fashion magazine, "the fine Italian hand of Ferragamo [is] eloquent in these handmade shoes which are made especially for, and imported by Saks Fifth Avenue in a myriad of colours and styles. As the creator of LIFTS and all manner of inspirational and unconventional footwear, Ferragamo has drawn half

⁶ Vogue USA, 91 (1), January 1, 1938, p. 58.

⁷ Italian Patent No. 353152, 6 October 1937 (Ricci, 2004, p. 87).

⁸ Vogue USA, 91 (1), January 1, 1938, p. 58.

⁹ Patent No. 15111, April 12, 1938 (Ricci, 2004, p. 88).

¹⁰ Patent No. 358887, February 9, 1938 (Ricci, 2004, p. 88).

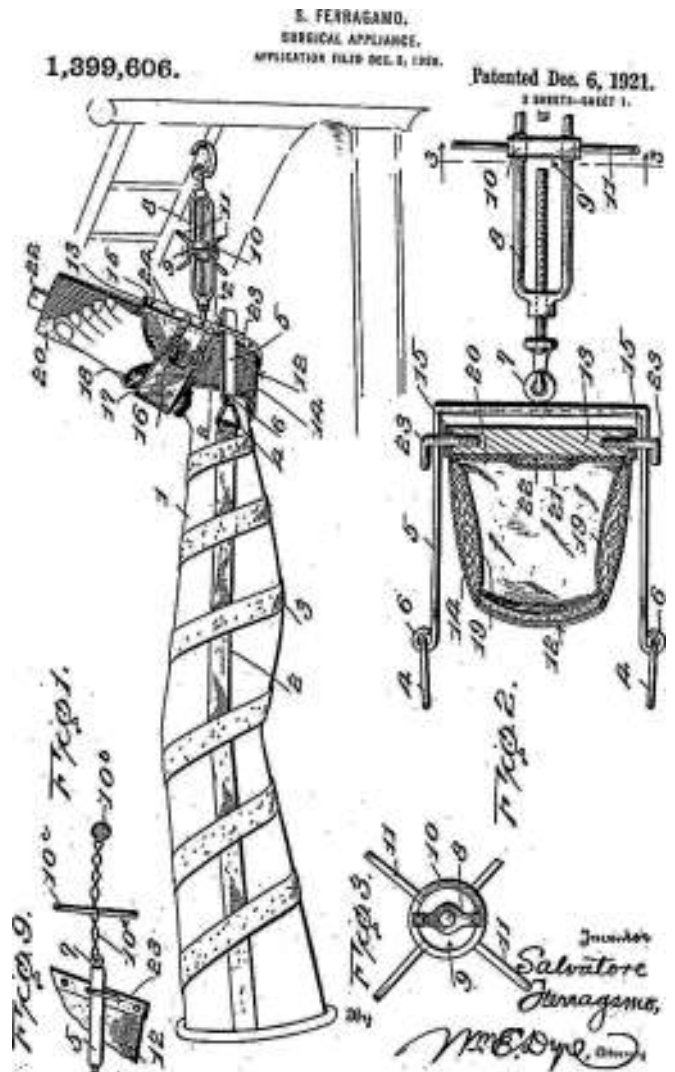

Fig. 4. Surgical appliance. Drawing, 1921. Source: Historical Archives of the United States Patent Office, Patent No. 1,399,606.

the continental beau monde to his smart little shop in Florence".¹¹ Not surprisingly, the Vogue advertisement emphasized the hand-made Italian production, thus implicitly juxtaposing it to American mass production. Yet, it should not go unnoticed that it mentioned that the ghillie shoe and the sandal were "U.S. design patented" and credited Ferragamo with being the designer who "regularly applied"¹² for the wedge (LIFTS). With the exception of the sandal, which cost \$18.50, the shoes were all advertised at \$15.75.¹³

The analysis of the patents registered by Ferragamo in the U.S. at the end of 1930s and of the Vogue advertisements allows us to put forward some provisional conclusions.

Firstly, shoe models could be on the market before being patented. This is the case of the ghillie shoes, which were advertised in January 1, 1938 and patented ten days later. Such a circumstance suggests that patents of designs were not intended to protect the inventor from copying. This hypothesis is confirmed by the fact that Herman Delman (1895–1955), who is remembered as the great

¹¹ Vogue USA, 91 (4), February 15, 1938, p. 3.

¹² Vogue USA, February 15, 1938, p. 3.

¹³ Exchange rate (1938): \$ 1 = lire 19.

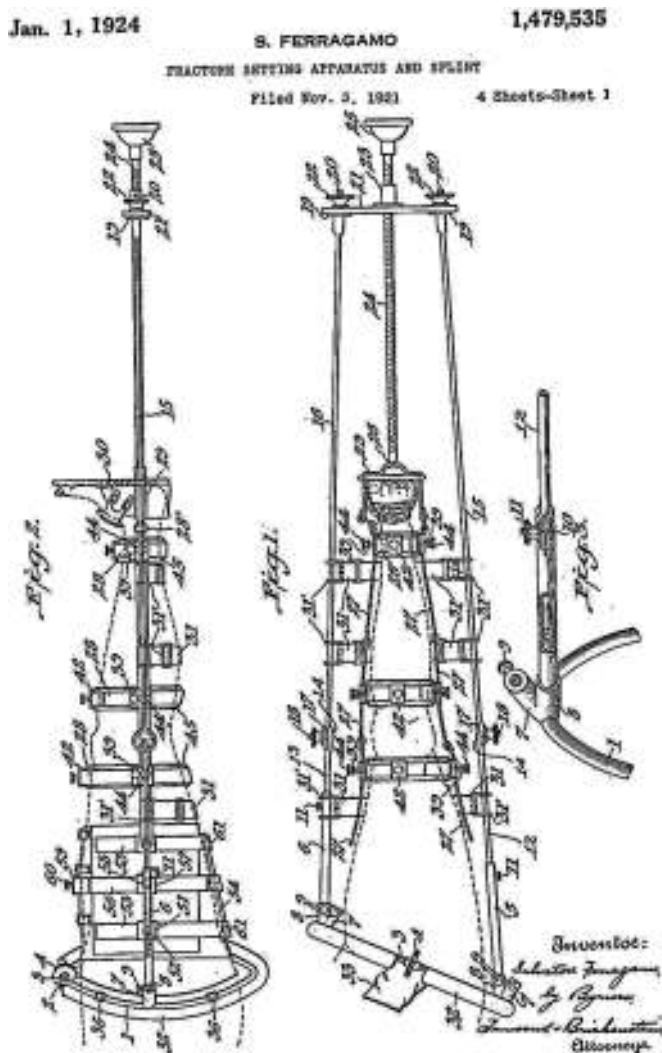

Fig. 5. Fracture setting apparatus and splint. Drawing, 1924. Source: Historical Archives of the United States Patent Office, Patent No. 1,479,535.

showman of the New York footwear industry,¹⁴ patented sandals with the uplift sole in 1939 and 1940.¹⁵

Secondly, patents did not give an extra economic value to the shoes, as proven by the fact that the ghillie shoes were marketed at the same price as Ferragamo's unpatented shoes equally advertised by *Vogue*. Bearing in mind that advertisement was addressed to the consumers; one must conclude that the mention of patents was supposed to affect the consumers' decisions about shopping. As a consequence, patents can be considered as being the expression of a customer-oriented industrial property law.

Thirdly, the advertisement described the materials the shoes were made of in detail. The list includes calf leather, cork, and suede, a particular kind of leather, usually kidskin, with the flesh side rubbed to make a velvety nap. At the time in the U.S., cork,

¹⁴ Targeting wealthy socialites and celebrities as his customers, Delman opened a small custom shoe shop on Madison Avenue in 1919. Gradually shifting his attentions to manufacturing, Delman hired top designers, most notably Roger Vivier, to create finely crafted, chic and luxurious footwear in stand out designs. Delman was a savvy promoter who realized that product image was paramount. He pioneered the practice of featuring film stars in his advertisements and partnered with exclusive clothing stores, including Saks and Bergdorf Goodman, to distribute his shoes.

¹⁵ Patents no. 118,616 and 118,617 both filed on November 24, 1939, and 120,500 filed on March 1, 1940.

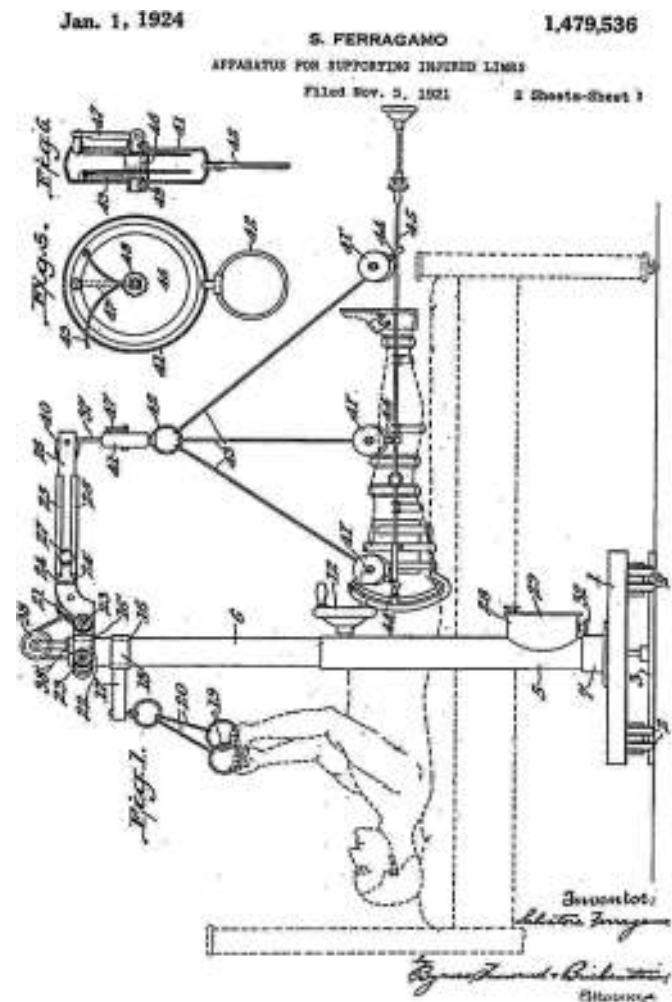

Fig. 6. Apparatus for supporting injured limbs. Drawing, 1924. Source: Historical Archives of the United States Patent Office, Patent No. 1,479,536.

and even more suede, were scantily used in shoe manufacturing.¹⁶ Along with the uplift sole and the laces, they endowed Ferragamo's shoes with those characteristics of absolute novelty and originality that made the patented design a template to be reproduced, improved and updated.

From the beginning of the 1930s, Ferragamo's activity as a prolific Italian inventor finds an extremely weak correspondence in the small number of patents he registered in the U.S. In our opinion, such a gap cannot be explained only in terms of nationality – incidentally, in the U.S. patents Ferragamo was mentioned as an American citizen resident in Italy – and even less by appealing to a generic feeling of patriotism. Delman was himself a scarcely fertile American patentee. He patented ten or so models from 1938 until 1940. The same applies to the French Roger Vivier and to Andre Perugia.

¹⁶ Still in the mid-1950s, kid leather was used in America primarily for gloves. In hopes of persuading American shoe manufacturers to begin using kidskin, then routinely used in European shoes, Charline Osgood – director of the Kid Leather Guild, a trade organization of American kid leather manufacturers – took annual trips to Europe between 1954 and 1959 to collect the finest high-style examples. During her travels she collected more than 170 pairs of shoes, primarily by prominent Italian makers such as Alberto Dal Cò, Rosina Schiavone Ferragamo, Armando Albanese, and Edoardo Frattegiani. The Osgood collection comprises 179 objects, chiefly fashionable Italian-made women's shoes. It was donated to the Brooklyn Museum in 1960. In 2009, it was transferred to The Costume Institute at the Metropolitan Museum of Art (Reeder, 2010, p. 241).

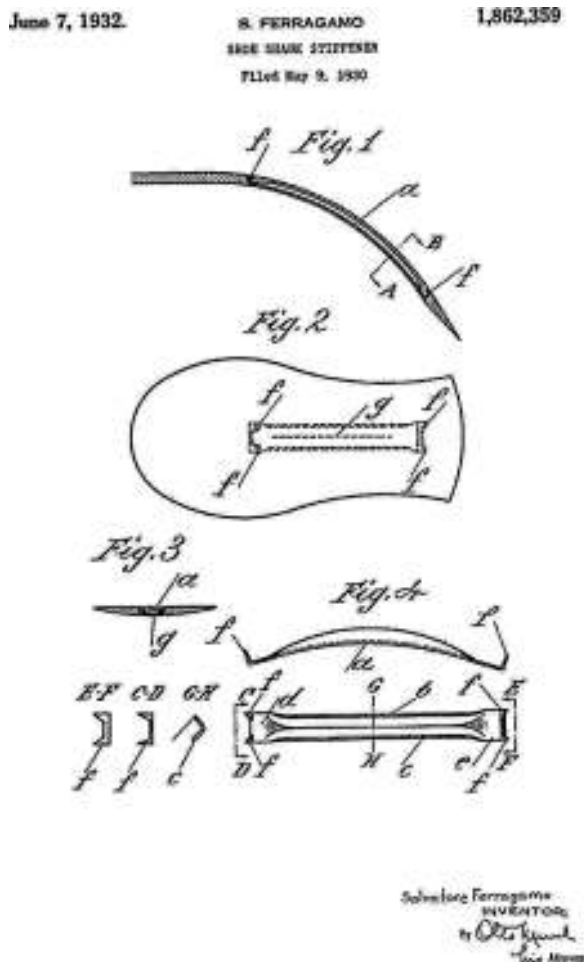

Fig. 7. Shoe shank stiffener. Drawing, 1932. Source: Historical Archives of the United States Patent Office, Patent No. 1.862.359.

Even more, the designs patented by them often share strong similarities. Among the group, Vivier is often credited with inventing the stiletto, yet there is no evidence that he did; who invented it still needs to be discovered and may in fact never be so. It was more of a group effort: one person coming up with the concept for the shoe, the other one refining that concept. Along with a few others, the designers named formed the international Gotha of ingenuity in shoemaking. In this respect, it can be said that the American patent was the juridical recognition of such a status.

For sure, in order to explain Ferragamo's activity as a prolific Italian inventor, one must bear in mind that the 1930s were marked in Italy by an increasing shortage of materials that were essential to shoemaking. In those years, austerity joined up with autarchy in turning economic isolation and self-reliance into a matter of Fascist pride. In response, Ferragamo began developing shoes manufactured with a variety of materials which were less expensive than leather – to a large extent imported – and could be easily found within the Italian market. Felt, raffia, metallic threads, cork, and skin from different kinds of animals, such as toads, fish and kids, thus became distinctive features of Ferragamo's ingenuity, as is proven by the remarkable number of patents he registered in the 1930s. Again, the importance of autarchy in explaining the outstanding number of Ferragamo's patents must be stressed, yet without its being overestimated. According to the historical sources, it increased from 97 (1929–1939) to 177 (1940–1945), but in the aftermath of World War II, when autarchy was disregarded and Salvatore Ferragamo achieved his greatest personal success as his shoe designs became known throughout the world, the number

of new patents filed amounted to 263 (1946–1951). Finally, more than 300 patents were registered in the 1950s (Ricci, 2004).

Rather, a comparison between the main aspects of the Italian legal system on the question of industrial property and the American one can provide us with more convincing explanations about the differences of attitude in patenting in the two countries.

According to Khan (2005), “the passage of the Sherman Act in 1890 was associated with a populist emphasis on the need to protect the public from corporate monopolies, including those based on patent protection”, thus sharpening the democratic attributes inherent in the American system of protection of intellectual property rights. Far from being discouraged, the inventors were incentivized to apply their ingenuity to the discovery of absolute novelties, a requirement rarely met by ornamental designs: “Upon occasion a decorative design may be patented although designers know that patent office refusals are more common than acceptances. The chief difficulty with this form of protection is the need for meeting the test of inventiveness, what we might look upon as absolute novelty or originality. Designs in textiles, garments, shoes, hats, handbags, furniture, and so on have been made for years, and a characteristic of many of the latest styles is a re-adaptation of some which had been the fashion years ago, since it is, in fact, exceedingly difficult to bring out a design in these trades which possesses the quality of inventiveness” (Hutchinson, 1940, p. 193). As a result, learning from patents was replaced by copying, a practice which in its turn was separated by a thin line from piracy, to the point that “the Shoe Fashion Guild found it necessary to patent an occasional design, and with this weapon a few threats of suits were sufficient to awe copyists who were, of course, not members of the Guild. Since it was quite costly to take back into stock a complete production of a style of shoe and non-members were never sure which designs had been patented, the latter learned not to copy any of the designs of guild members” (Hutchinson, 1940, p. 193). Not surprisingly, the name Delman appeared in every shoe he manufactured, thus securing his company's reputation and success by resorting to trademarking instead of patenting.

As heir to the law in force in the Kingdom of Savoy, which was strongly influenced by the pre-revolutionary French tradition, the Italian system conceived patent as a kind of monopoly (*privativa*). As a result, the applicant's resolution, initially put to the test by a laborious bureaucratic procedure, was then imposed on by expensive taxes which could definitely discourage him/her from patenting.¹⁷ Thus, the Italian law was not aimed at making patents within everyone's means. The patentee was given the status of privileged recipient, thus emphasizing the individual advantages arising from ingenuity rather than the social benefits.

The hundreds of patents registered by Ferragamo between 1929 and 1960 prove that he was well aware of the advantages offered by them. We must suppose that the prominent Italian shoemakers at the time – Alberto Dal Cò, Armando Albanese, Edoardo Frattegiani, and Ferragamo's sister Rosina Schiavone – were well aware too. Yet, unlike him, they did not patent although they made an equally imaginative use of materials and forms. In our opinion the reason why Ferragamo was an atypical Italian patentee is twofold. The first one is grounded in his close acquaintance with the American approach to patenting and with the American market. They both had taught him that the patent gave the designer the status

¹⁷ Comparing the industrial property laws in force at the end of the 19th century in the main European countries to the law in force in Piedmont since 1826, an Italian jurist stated that it did not require any charge, but that the applicant had to pay expenses and extra costs to such an extent that eventually they amounted to a heavy tax (Cottarelli, 1888, p. 172). The expenses the inventor was liable for, listed in Borghese and Brevetti (1951, p. 55) indicate that the administrative practice and usage had not changed in the meantime.

(8)

Jan. 11, 1938. S. FERRAGAMO
SHOE OF SIMILAR ARTICLE
Filed Nov. 20, 1937
Des. 107,858

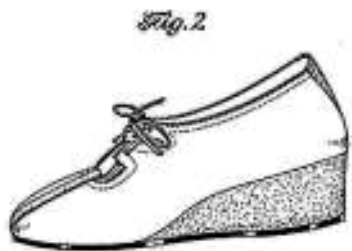
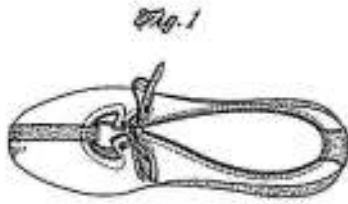

INVENTOR
BY *Salvatore Ferragamo*
Carlo G. Blum
ATTORNEY.

(9)

Jan. 11, 1938. S. FERRAGAMO
SHOE OF SIMILAR ARTICLE
Filed Nov. 20, 1937
Des. 107,859



INVENTOR
BY *Salvatore Ferragamo*
Carlo G. Blum
ATTORNEY.

(10)

March 1, 1938. S. FERRAGAMO
SHOE OF SIMILAR ARTICLE
Filed Jan. 20, 1938
Des. 108,610

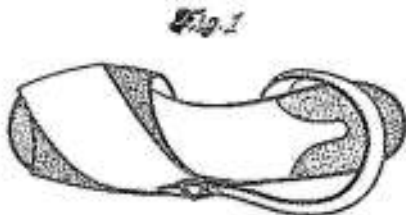

INVENTOR
BY *Salvatore Ferragamo*
Carlo G. Blum
ATTORNEY.

(11)

March 1, 1938. S. FERRAGAMO
SHOE OF SIMILAR ARTICLE
Filed Jan. 20, 1938
Des. 108,620

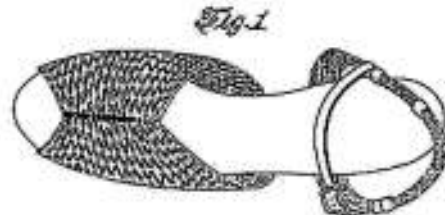

INVENTOR
BY *Salvatore Ferragamo*
Carlo G. Blum
ATTORNEY.

Figs. 8–11. Drawings of models patented by Ferragamo in the U.S., 1930s. Source: Historical Archives of the United States Patent Office.

of fashion inventor; the market turned him into a fashion originator by selecting the ideas to be turned into marketable goods. The second and consequent reason concerns the scale of production. Ferragamo diversified hand- and custom-made production from machinery production, thus developing shoe manufacturing on an industrial scale. By 1950 he employed some 700 workers who produced 350 handcrafted and, for the most part, custom-fitted shoes per day. From then on he began to mechanize non-critical areas of the shoemaking process in order to meet the increasing demands of both the Italian and the American market (Cohen, 2014). As a result, patents, which were mentioned in association with the name of the department stores in the 1930s, became suitable for licensing from the 1950s. Leading to the industrialization of his work for mass production, Ferragamo signed a deal with an English manufacturer for producing shoe made entirely by machine under the label “Ferrina Shoes” (Oliva, 2008, p. 52).

5. Conclusion

Why did Salvatore Ferragamo patent inventions and ornamental models concerning whole shoes as well as parts of them with increasing regularity? And what does his attitude as an inventor tell us about product innovation in the footwear industry?

Between the 19th and the 20th centuries, shoe manufacturing was profoundly transformed by a rapid process of industrialization (whose motor force was the progressive adoption of machinery in all the production phases) and which developed in the USA to then spread out across the European continent. It can be stated that, without any doubt, a determining role in this transformation was played by product innovation that made footwear a product destined for the mass market. However, shoes were an element in clothing, which, as such, at least from Mediaeval times, were linked to the “fashion factor”, that is, subject to variations in taste to which it was necessary to adapt. In the footwear sector – just as in that of made garments – the increased productivity that fed a growing mass market did not correspond to the needs of the consumers for whom footwear represented the completing element of a fashionable look. In the *haut de gamme* segment of the market, producers were established who, up to the 1930s, occupied a position midway between industry and artisanship, but, who, like Salvatore Ferragamo, had recourse to patenting as a product innovation strategy. The analysis of the Ferragamo case allows us to advance some hypotheses on the reasons which explain why the registration of models was so widely adopted in the footwear sector. It is probable that in the production area of footwear, the rapid pace of process innovation had played a role in the early approach of the protagonists to the procedure for the granting of patents, even if initially these concerned machinery rather than shoe models; in fact, Salvatore Ferragamo’s American experience might have contributed to developing this type of awareness. Secondly, if it is true that design played an important role in making footwear fashionable, it is also true that that the technological devices that made the shoe more comfortable could not be overlooked; in this case a patent represented a solution which was worthy of attention in protecting the innovation. In fact, we have recalled the commitment which Salvatore Ferragamo had dedicated to research in innovative materials in the period of the Fascist Autarchy. We may consider that “the fashion industry’s primary use of design patents has been in the world of handbags and shoes, which tend to have slower turnover in style” (Raustiala and Sprigman, 2012, p. 12). The Salvatore Ferragamo case further shows that a patent could also serve as an instrument in promoting the product, and, going further, it would be possible to make the hypothesis that ample recourse to patenting aimed at conferring a position and a strong identity on the

product in an age in which the brand had not yet taken on these functions.

Usually considered to be an indicator of inexhaustible creativity, the number of patents registered by Ferragamo also provides us with a measure of the progressive transformation of his firm from a craft-based workshop into an industrial company. Ferragamo’s shoes dressed the feet of internationally well-known women. The aura of a legend which surrounded him fed the myth of the poor emigrant who ascended to the top of the international Gotha of fashion designers. Yet, to run the business profitably required more prosaic livelihoods such as proceeds resulting from the cession of property rights, revenues stemming from licensing, and earnings deriving from selling shoes to the American department stores. Artisans patent their inventions only occasionally, as if to protect trade secrets. The industrial entrepreneurs’ approach to property rights is quite different in that they patent inventions regularly in order to fully exploit their economic potential.

Indeed, Salvatore Ferragamo was first and foremost a designer. Looking at his patents, including those registered in the U.S. at the beginning of the 1920s, one must recognize that all of them have a direct bearing on creating comfort, conceived of as physical ease and well-being, for the human body. He had assumed the shoes would be functional, thus becoming the forerunner of the generation of Italian industrial designers credited with being responsible for the increasing acceptance gained by Italian products in the international markets from the 1950s onwards. They conceived of design as a combination of research, innovation and engineering aimed at creating practical and aesthetic consumer goods, which were also attractive by virtue of the social values and cultural significance they conveyed to their users. They were projected to be reproduced on an industrial scale. Their success depended on the extent to which they grasped the essentials of materials, shapes, and technology and put them together with an eye for reducing the production costs. The uplift sole is a typical example of industrial design. An evidence of Ferragamo’s boundless ingenuity, it calls for a careful consideration of him as a designer deeply involved in laying the foundation of an industrial company.

Salvatore Ferragamo designed and patented shoes which have become part of fashion history. Therefore, he can be considered to be also the precursor of those fashion designers who invented Italian ready-to-wear, the new kind of fashion conceived as being produced and reproduced on an industrial scale which gained increasing acceptance on the international markets from the 1970s onwards. Their rise to international standing marked the beginning of a new era in fashion history. From then on, fashion companies have become entities which are increasingly independent of manufacturing firms. The brand has risen to a princely status among financial assets, thus moving the core of the business from manufacturing management to marketing and brand management. Not surprisingly, the successors to the founder at the helm of the family business soon abandoned the practice of patenting inventions and ornamental models after his death. They instead favoured exploiting them, along with the prototypes created by the shoemaker of dreams and kept in the company’s historical archives, as an endless source of inspiration and as a model of cultural heritage, enhancing the values and meanings conveyed by the Ferragamo brand.

References

- 1921. [Annual Report of the Commissioner of Patents.](#)
- 1924. [Annual Report of the Commissioner of Patents.](#)
- Borghese, S., Brevetti, I., 1951. [Guida pratica per la richiesta di brevetti per marchi di impresa, invenzioni e modelli industriali.](#) Pirola, Milano.
- Bravo, G., Merlo, E., 2002. [Sviluppo e crisi del distretto di Vigevano.](#) In: Provasi, G. (Ed.), [Le istituzioni dello sviluppo. I distretti industriali tra storia, sociologia ed economia.](#) Donzelli, Rome, pp. 43–98.
- Chantrell, L., 1978. [Les Moires 1895–1927 – Mesdames Callot soeurs. La Pensée universelle, Paris.](#)

- Church, R.A., 1968. The effect of the American export invasion on the British boot and shoes industry. *Journal of Economic History* 28 (2), 223–254.
- Church, R.A., 1970. Labour supply and innovation 1800–1860: the boot and shoes industry. *Business History* 12 (1), 25–45.
- Cohen, M.L., 2014. Salvatore Ferragamo S.p.A. In: Hill, K. (Ed.), *International Directory of Company Histories*, vol. 150. Gale, Detroit.
- Cottarelli, F., 1888. *Le privative industriali*. Tipografia sociale, Cremona.
- Ferragamo, S., 1985. *Shoemaker of Dreams: The Autobiography of Salvatore Ferragamo*. Giunti, Firenze.
- Fontana, G.L., Franceschetti, G., Roverato, G., 1998. *100 anni di industria calzaturiera nella Riviera del Brenta*. La Press, Fiesco d'Artico, VE.
- Franceschelli, V. (Ed.), 2003. *Brevetti, marchio, ditta, insegna*. UTET, Torino.
- Freeman, C., 1974. *The Economics of Industrial Innovation*. Penguin, Harmondsworth.
- Hutchinson, K.D., 1940. Design piracy. *Harvard Business Review* 18, 191–198.
- Giannetti, R., 1998. *Tecnologia e sviluppo economico italiano 1870–1990*. Il Mulino, Bologna.
- Khan, Z.B., 2005. *The Democratization of Invention: Patents and Copyrights in American Economic Development, 1790–1920*. Cambridge University Press, New York.
- Le Bot, F., Perrin, C., 2012. El Estado y la industria del calzado en Francia en el siglo XX. La definición de una escala territorial para la coordinación entre los poderes públicos y las empresas. *Investigaciones de Historia Económica* 8, 15–28.
- Le Bot, F., 2005. La 'famille' du cuir contre Bata: malthusianisme, corporatisme, xénophobie et antisémitisme dans le monde de la chaussure en France, 1930–1950. *Revue d'Histoire Moderne et Contemporaine* 52 (4), 131–151.
- Levitt, S., 1986. *Victorians Unbuttoned. Registered Designs for Clothing, their Makers and Wearers, 1839–1900*. George Allen & Unwin, London.
- Lupano, M., Vaccari, A. (Eds.), 2009. *Una giornata moderna. Moda e stili nell'Italia fascista*. Damiani Editore, Bologna.
- Marcucci, R., 2004. *ANIBO e made in Italy: storia dei buying offices in Italia*. Vallecchi, Firenze.
- Martelli, M., 2011. *Models, trademarks and inventions from the Italian Patent and Trademark Office, held in the Central State Archives*. In: Sette, A.M. (Ed.), *Drawing and Design – Italian Patents and Creativity*. Marsilio Editori, Venezia, pp. 389–394.
- Ministero dell'industria del commercio e dell'artigianato (Ed.), 2000. *La tutela della proprietà industriale*. Ministero dell'industria del commercio e dell'artigianato, Roma.
- Miranda, J.A., 2004. American machinery and European footwear: Technology transfer and international trade, 1860–1939. *Business History* 46 (2), 195–218.
- Miranda, J.A., 2009. Competing in fashion goods: firms and industrial districts in the development of the Spanish Shoe Industry. *Business and Economic History On-Line* 7, 1–34.
- Oliva, N., 2008. *Moda e imprese nella storia dell'economia italiana: la Ferragamo S.p.A e i suoi bilanci*. Rirea, Roma.
- Raustiala, K., Sprigman, C., 2012. *The Knockoff Economy. How Imitation Sparks Innovation*. Oxford U.P., Oxford.
- Reeder, J. (Ed.), 2010. *High Stile: Masterworks from the Brooklyn Museum Costume Collection at The Metropolitan Museum of Art*. Metropolitan Museum of Art, New York.
- Ricci, S., 2004. *Museo Salvatore Ferragamo. Ideas, Models, Inventions, Sillabe*. Livorno.
- Rosenberg, N., Mowery, D., 1998. *Paths of Innovation. Technological Change in 20th-Century America*. Cambridge U.P., Cambridge.
- Sabbatucci Severini, P., 2007. *Industria e territori. La produzione di calzature in Italia (1890–1970)*. In: Moroni, M. (Ed.), *Lo sviluppo locale. Storia, economia, sociologia*. Il Mulino, Bologna, pp. 95–124.
- Sáiz González, J.P., 1999. *Patentes e innovación en la España Contemporánea*. Oficina Española de Patentes y Marcas, Madrid.
- Scherer, F.M., 1965. Firm size, market structure opportunity and the output of patented inventions. *American Economic Review* 3, 1097–1125.
- Schmookler, J., 1966. *Inventions and Economic Growth*. Harvard U.P., Cambridge, MA.
- Segreto, L., 1989. L'industria calzaturiera in Italia, La lunga rincorsa marchigiana, 1914–1960. In: Anselmi, S. (Ed.), *L'industria calzaturiera marchigiana. Dalla manifattura alla fabbrica*. Unione Industriali del Fermano, Fermo, pp. 247–323.
- Stewart, M.L., 2005. Copying and copyrighting haute couture: democratizing fashion, 1900–1930s. *French Historical Studies* 28 (1), 103–130.
- Sutthiphisal, D., 2006. The geography of invention in high- and low-technology industries: evidence from the second industrial revolution. *Journal of Economic History* 66, 492–496.
- Thomson, R., 1991. Crossover inventors and technological linkages: American shoemaking and the broader economy. *Technology and Culture* 32 (4), 1018–1046.
- Thomson, R., 2010. The continuity of innovation: the civil war experience. *Enterprise and Society* 11 (1), 128–165.