

ORIGINAL ARTICLE

Spanish validation of the Parental Acceptance Questionnaire (6-PAQ)



Juan M. Fluja-Contreras^{a,b,*}, Azucena García-Palacios^{c,d}, Inmaculada Gómez^{a,b}

^a Department of Psychology of University of Almeria, Spain

^b Health Research Centre of University of Almeria, Spain

^c Department of Psychology, University Jaume I, Castellon, Spain

^d CIBER of Physiopathology of Obesity and Nutrition CIBERobn, CB06/03 Instituto de Salud Carlos III, Spain

Received 4 November 2019; accepted 11 March 2020

Available online 16 April 2020

KEYWORDS

Psychological flexibility;
Family;
Children;
Instrumental study

Abstract

Background/Objective: Psychological flexibility is an ability with positive effects in health, also in the field parenting. The aim of this study is to validate the Parental Acceptance Questionnaire (6-PAQ) in Spanish sample.

Method: A total of 426 parents (96.3% female), with an average age of 38.25 years ($SD = 5.76$) and with at least one child between 3 and 16 years old participated. Participants completed the 6PAQ and other instruments assessing experiential avoidance, thought suppression, satisfaction with life and symptoms of anxiety and depression.

Results: In comparison with the original model, the three-factor structural solution with 16 items obtained a better adjustment ($CFI = .996$; $GFI = .998$; $TLI = .995$; $RMSE = .016$) that refer to response styles related to psychological flexibility (open, aware and active). The 6-PAQ adaptation has shown good internal consistency, with a Cronbach alpha of .81 and a McDonald's omega of .86 for the scale, and evidence of convergent validity with significant correlations with measure of avoidance, thought suppression, satisfaction with life and anxiety.

Conclusions: The Spanish version of the 6-PAQ with the three-factor structure presents psychometric property to be considered a reliable measure and a valid instrument for the evaluation of parental psychological flexibility.

© 2020 Asociación Española de Psicología Conductual. Published by Elsevier España, S.L.U. This is an open access article under the CC BY-NC-ND license (<http://creativecommons.org/licenses/by-nc-nd/4.0/>).

* Corresponding author: Universidad de Almería, Edificio Departamental C, Despacho 1,31. La Cañada de San Urbano s/n, 04120 Almería, Spain.

E-mail address: jfc397@ual.es (J.M. Fluja-Contreras).

PALABRAS CLAVE

Flexibilidad psicológica; familia; niños; estudio instrumental

Spanish validation of the 6-PAQ**Resumen**

Antecedentes/Objetivo: La flexibilidad psicológica es una habilidad que tiene efectos positivos en la salud, y también en el ámbito de la parentalidad. El objetivo del estudio es validar el *Parental Acceptance Questionnaire* (6-PAQ) en población española.

Método: Participaron 426 padres (96,30% mujeres), con una media de edad de 38,25 años ($DT=5,76$) y con al menos un hijo entre 3 y 16 años. Los participantes completaron el 6-PAQ y otros cuestionarios de evitación experiencial, supresión de pensamientos, satisfacción vital, y sintomatología de ansiedad y depresión.

Resultados: En comparación con el modelo original se obtiene un mejor ajuste para la estructura factorial de tres factores con 16 ítems ($CFI=0,996$; $GFI=0,998$; $TLI=0,995$; $RMSE=0,016$) que hacen referencia a estilos de respuesta relacionados con la flexibilidad psicológica (abierto, centrado y comprometido). Los resultados mostraron una buena consistencia interna, con una alfa de Cronbach de 0,81 y un omega de McDonald de 0,86, así como evidencias de validez convergente con correlaciones significativas con medidas de evitación, supresión de pensamientos, satisfacción vital y ansiedad.

Conclusiones: La versión española del 6-PAQ, con estructura de tres factores, presenta propiedades psicométricas para considerarse una medida fiable y un instrumento válido para la evaluación de la flexibilidad psicológica parental.

© 2020 Asociación Española de Psicología Conductual. Publicado por Elsevier España, S.L.U. Este es un artículo Open Access bajo la licencia CC BY-NC-ND (<http://creativecommons.org/licenses/by-nc-nd/4.0/>).

Psychological flexibility is defined as the skill of coming into full contact with thoughts and emotions in the present moment with no intention of modifying or changing these private events, and depending on the situation, persisting in behavior in the direction of personal goals and values (Hayes, Strosahl, & Wilson, 2012). In this sense, we understand parental psychological flexibility as the ability to "accept thoughts and negative emotions related to their child as they occur, while acting to maintain a good parent-child relationship consistent with good parenting practices" (Burke y Moore, 2015, p. 549). Psychological flexibility has been described based on six interconnected processes: acceptance, defusion, being present, self-as-context, committed actions and values (Hayes, Luoma, Bond, Masuda, & Lillis, 2006). Later, this model was simplified and the six processes were organized in three dyads defined as open, aware and active response styles (Hayes et al., 2012) which somehow fits other flexibility analyses (Gootzeit, 2014; Harris, 2019).

Psychological flexibility has been explored as a general health factor (Kashdan & Rottenberg, 2010; Kuba et al., 2019; Pagnini et al., 2019; Wersebe, Lieb, Meyer, Hofer, & Gloster, 2018). In the scope of parenting, effects have been found between psychological flexibility and parenting leading to more positive practices, which in turn are associated with children with fewer internalizing and externalizing problems (Brassell et al., 2016) and greater psychological flexibility (Williams, Ciarrochi, & Heaven, 2012). Relationships have been found between more psychological inflexibility and stress, anxiety (Emerson, Ogielka, & Rowse, 2019) and depression (Biglan et al., 2015) in both parents and children. Furthermore, psychological inflexibility can have the effect of maintaining maladaptive parenting styles

with aversive functions under excessive avoidance and cognitive fusion of private events that cause distress (Brown, Whittingham, & Sofronoff, 2015; Whittingham & Coyne, 2019).

The instrument most widely used for evaluating psychological flexibility in adults is the Acceptance and Action Questionnaire (AAQ-II; Bond et al., 2011), which has been the basis for versions and adaptations for specific contexts (Ong, Lee, Levin, & Twohig, 2019). Among these instruments are some developed specifically for evaluating parental psychological flexibility, such as the Parental Acceptance Questionnaire (Cheron, Ehrenreich, & Pincus, 2009), which consists of two inaction and non-acceptance scales; the Parenting-Specific Psychological Flexibility (Brassell et al., 2016); the Parental Flexibility Questionnaire (Burke & Moore, 2015), which evaluates three factors: cognitive fusion, acceptance and committed action; and the Parental Acceptance Questionnaire (Greene, Field, Fargo, & Twohig, 2015), which evaluates psychological flexibility based on the six processes in the model mentioned above.

Psychological flexibility instruments specifically for mothers and fathers are necessary to analyze their parenting styles and the effects of interventions emerging in this scope in Clinical and Educational Psychology (Whittingham & Coyne, 2019). However, none of those specific questionnaires have been validated in a Spanish population.

Therefore, the objective of this study was to adapt and explore the psychometric properties of the Parental Acceptance Questionnaire (6-PAQ; Greene et al., 2015) in a Spanish population, specifically, mothers and fathers with children three to sixteen years old. This instrument was selected from those mentioned above because it is the only one that evaluates the six parental psychological flexibil-

Table 1 Demographic data of the sample ($N = 426$).

Age, mean (SD)	38.29 (5.75)
Sex, n (%)	Female: 410 (96.50) Male: 16 (3.50)
Marital status, n (%)	Married: 330 (77.40) Single: 38 (8.90) Single parent: 13 (3.10) Separated: 26 (6.10) Divorced: 13 (3.10) Widow/er: 5 (1.20)
Education level, n (%)	Primary: 59 (13.80) Secondary: 143 (33.30) Superior: 225 (52.80)
Number of children, n (%)	1 child: 126 (29.60) 2 children: 248 (58.20) 3 children: 44 (10.30) 4 children: 7 (1.60) 5 children: 1 (0.20)
Children's age, mean (SD)	5.77 (2.10)
Sex of children, n (%)	Female: 288 (49.50) Male: 293 (50.40)

ity processes. Specifically analyzed were reliability, factor structure and relationships with other variables associated with parental psychological flexibility. Thus, the following hypotheses were posed:

- 1 The factor structure is similar to the one proposed in the original structure (Greene et al., 2015), that is, a six-factor scale related to the six psychological flexibility processes.
- 2 There is a positive relationship between the variables evaluated by the 6-PAQ and other avoidance, thought suppression, dissatisfaction with life, anxiety (Emerson, Ogielka, & Rowse, 2019) and depression variables (Biglan et al., 2015).

Method

Participants

The original study sample was incidental, recruited from the general population, and was comprised of 676 mothers and fathers. The inclusion criteria were: (a) father or mother of at least one child aged three to sixteen, (b) speak Spanish and have no linguistic barriers for filling in the instruments, (c) the children had not been diagnosed with any psychological disorder or medical disease, and (d) the parent had not been diagnosed with any psychological disorder or medical disease. Of the original sample, 250 participants were eliminated because they did not meet these inclusion criteria. The final sample was therefore comprised of 426 participants (Table 1), of whom 96.3% were mothers aged 25 to 55, with a mean age of 38.25 ($SD = 5.76$), 69.9% of the sample were married, and 52.7% of the participants had a higher education. All of them were Spaniards, most of them residents in Andalusia (56.3%) and had a mean of 1.85 children ($SD = 4.85$). Finally, of the 426 participants, 156 did not fill

in all of the instruments and therefore, there were only 274 participants in the construct validity analysis sample.

Instruments

Parental Acceptance Questionnaire (6-PAQ; Greene et al., 2015). The 6-PAQ is a scale for fathers and mothers who evaluate the six psychological flexibility processes related to their children's upbringing. It consists of 18 items rated on a Likert-type scale from 1 (*strongly disagree/never*) to 4 (*strongly agree/always*), which are divided into six scales corresponding to the psychological flexibility processes, that is acceptance, defusion, being present, self-as-context, values and committed actions. A higher score is interpreted as more parental psychological inflexibility or difficulties on each of the subscales. The original questionnaire has an internal consistency of .88 for the global scale, and from .60 to .83 for the subscales (Appendix 1).

Acceptance and Action Questionnaire (AAQ-II; Bond et al., 2011; Ruiz, Langer Herrera, Luciano, Cangas, & Beltran, 2013). This was used to evaluate experiential avoidance and psychological inflexibility. It consists of seven items on a seven-point Likert scale. The Cronbach's alpha is .88.

White Bear Suppression Inventory (WBSI; Wegner & Zanakos, 1994; González Rodríguez, Avero Delgado, Rovella, & León, 2008). This scale evaluates the general tendency to suppress thoughts. It is comprised of 15 items on a five-point Likert-type scale which are divided into two subscales: Undesired intrusive thoughts and Self-distraction and thought suppression. It has a Cronbach's alpha of .89 for the total score and .87 and .80 on the subscales, respectively.

Satisfaction with Life Scale (SWL; Diener, Emmons, Larsen, & Griffin, 1985; Vázquez, Duque, & Hervás, 2013). It was used to evaluate overall satisfaction with life. The scale is comprised of five items on a seven-point Likert scale. It has a Cronbach's alpha of .88.

Beck Anxiety Inventory (BAI; Beck, Epstein, Brown, & Steer, 1988; Magán, Sanz & García-Vera, 2008). This evaluates clinical anxiety. The instrument consists of 21 items on a four-point Likert scale from 0 to 3. It has a Cronbach's alpha of .91.

Beck Depression Inventory (BDI-II; Beck, Steer, & Brown, 1996; Sanz, Perdigón, & Vázquez, 2003). This was used to evaluate depressive symptomatology in the last week. It consists of 21 items on a Likert scale from 0 to 3 points. The Cronbach's alpha is .91.

Procedure

First, permission was received from the original authors to validate the instrument in a Spanish population. Then it was translated from English to Spanish using the back-translation technique (Hambleton, 2005). The study was approved by the Scientific Committee of the University of Almeria. The sample was recruited from the general population by incidental sampling through collaborating institutions and social networks. The instruments were completed anonymously on paper or on the LimeSurvey online survey platform. Before filling in the instruments, the participants signed their informed consent or checked the box for it. In both formats, administration was individual and self-applied. The

Table 2 Descriptive analysis of items.

Item	<i>M</i>	<i>SD</i>	Skewness	Kurtosis	Discrimination index
1*	2.04	0.72	0.50	0.57	0.54
2*	1.72	0.60	0.41	0.84	0.61
3	1.93	0.70	0.34	0.02	0.71
4	2.31	0.75	0.16	-0.12	0.79
5*	1.50	0.59	0.87	0.93	0.61
6	1.36	0.55	1.35	1.95	0.48
7*	2.53	0.77	0.03	-0.26	0.19
8	2.06	0.75	0.33	-0.06	0.83
9	2.02	0.78	0.32	-0.37	1.15
10*	1.70	0.58	0.26	0.24	0.68
11	2.00	0.79	0.46	-0.15	1.08
12	1.44	0.62	1.16	0.91	0.75
13	2.09	0.83	0.46	-0.16	1.25
14	1.33	0.62	1.73	2.40	0.61
15*	2.15	0.80	0.52	0.12	0.50
16	1.47	0.62	1.06	0.71	0.85
17	2.33	0.80	0.16	-0.30	0.68
18*	1.73	0.60	0.40	0.80	0.58

Note: * reverse items.

participants who completed the questionnaires on paper were invited to participate by the technician or psychologist at collaborating institutions, who gave them the questionnaires in an envelope which the participant returned sealed. If the participants answered online, they completed the self-applied form on the platform. This Web procedure enabled better control of database quality (Muñiz & Fonseca-Pedrero, 2019). The participation instructions indicated the approximate time for completion (15 minutes) and it was recommended that they do so when they had this much time to respond without interruption. They were also given a contact email address and phone number for any questions related to the questionnaires or their consent, but none of the participants made use of this assistance.

A sample of 18 mothers and fathers completed the pilot questionnaire to ensure there were no problems in understanding the items, on which they reported a mean score of 3.33 ($SD=0.59$) on a four-point Likert scale. All of them said they had understood all the items on the instrument.

Data analysis

The analyses were performed with the SPSS v.21 and R Studio statistics programs. First, a descriptive analysis was performed of the items and the variables in the original instrument. The factor structure was evaluated with a confirmatory factor analysis (CFA) using the diagonally weighted least squares (DWLS) procedure with polychoric correlations due to the nature of the variables (Brown, 2006). Goodness of fit of the model was analyzed with the following indices (Jackson, Gillasp, & Purc-Stephenson, 2009): Chi-squared; Comparative Fit Index (CFI), Goodness-of-Fit Index (GFI), Tucker-Lewis Index (TLI), and Root Mean Square Error of Approximation (RMSEA) with a 90% confidence interval. The six-factor structure of the original instrument, a unidimensional model and a second-order three-factor model with

six first-order factors were explored. The Cronbach's alpha coefficient and the McDonald's omega (1999) were employed to evaluate the internal consistency of the items on the instrument and its subscales. The test information function was analyzed to evaluate the accuracy from the perspective of item response theory (IRT) (Muñiz, 2018). The means and standard deviations were found for the global 6-PAQ score and its subscales, and the means were compared based on different sociodemographic variables using the Student's *t* and ANOVA, estimating the effect size of the scores with statistically significant differences with the Cohen's *d* (1988). Finally, to explore the evidence of validity of the relationship with other variables, the correlations of the global score and the subscales were examined with the experiential avoidance (AAQ-II), thought suppression (WBSI), life satisfaction (SWL), anxiety (BAI) and depression (BDI) scales using the Pearson correlation index. Partial data lost, that is, non-response to study variables, were not included in the data analysis, in other words, were not entered.

Results

Descriptive analysis of the items

The mean score of the total sample ($N=426$) on the instrument was 33.70 ($SD=5.91$). Table 2 shows the results of the descriptive analysis of the items. The mean scores on the items ranged from 1.35 (Item 6) to 2.52 (Item 7). The standard deviation ranged from 0.54 (Item 6) to 0.82 (Item 13). The median skewness (absolute) was 0.47 and kurtosis 0.39. The discrimination indices of the items were over 0.40, except for Item 7 (0.19). Items 1, 2, 5, 7, 10, 15 and 18 were reverse-scored.

Table 3 Fit indices.

	χ^2	<i>df</i>	CFI	GFI	TLI	RMSEA	90% CI (low-high.)
6 Factor model	184.70	120	.975	.997	.968	.036	(.025 - .045)
Unidimensional	347.24	135	.918	.994	.907	.061	(.053 - .069)
3 Factor model	105.24	95	.996	.998	.995	.016	(0 - .031)

Note. χ^2 = Chi Square; *df* = degrees of freedom; CFI = Comparative fit index; GFI = goodness of fit index; TLI = Tucker-Lewis index; RMSEA = root mean square error of approximation (confident interval of 90% between brackets).

Confirmatory Factor Analysis and reliability

First, a confirmatory factor analysis (CFA) was performed following the factor structure proposed by the authors of the original scale (Greene et al., 2015), in which the items were distributed in the six factors of psychological flexibility (upper construct). Table 3 shows the model's fit indices. However, there was high correlation between the defusion and self-as-context ($r = .94$), committed actions and values ($r = .70$), acceptance and defusion ($r = .77$) and being present and self-context ($r = .82$) constructs, which is an indication that they may be unidimensional factors. Furthermore, two items, Item 1 (.22) and Item 7 (.09) had low factor loadings. With this structure, the 18-item questionnaire shows internal consistency of .79 with the Cronbach's alpha and .80 with the McDonald's omega coefficient. The subscales also had the following reliability coefficients: Acceptance ($\alpha = .56$; $\omega = .57$), Defusion ($\alpha = .56$; $\omega = .65$), Being present ($\alpha = .34$; $\omega = .47$), self-as-context ($\alpha = .66$; $\omega = .66$), Values ($\alpha = .67$; $\omega = .67$) and Value-based action ($\alpha = .38$; $\omega = .52$).

Second, a CFA was performed with a unidimensional model (see Table 3 for fit indices) in which the factor loading found was low for items 1 (.25) and 7 (.00). Internal consistency remained the same as in the previous model ($\alpha = .79$; $\omega = .80$).

Finally, considering the results of the analyses above, a new CFA was performed. Given the high correlation between the factors and the low internal consistency, a second-order three-factor model with six first-order factors was proposed in line with the model previously proposed by other authors (Gootzeit, 2014; Harris, 2019; Hayes et al., 2012). Items 1 and 7, which had low factor loadings and low discrimination were also eliminated. Figure 1 shows the model's factor distribution. There was high correlation between the second-order and first-order factors for each scale except for Being present, for which correlation is moderate, showing that these subfactors are part of the second-order factors. Table 3 shows the model fit indices. The reliability analyses showed acceptable internal consistency. The Cronbach's alpha coefficient was 0.81 and the McDonald's omega coefficient was 0.86. Internal consistency indices were also acceptable for the Open ($\alpha = .71$; $\omega = .72$), Aware ($\alpha = .67$; $\omega = .68$) and Active factors ($\alpha = .66$; $\omega = .68$).

Figure 2 illustrates the information function test of the scale on the sum of the information functions of the 16 items and their standard error. The extreme scores show a decrease in the accuracy of the test measurements, that is, as the number of items increases so does their accuracy. The test provides the largest amount of information around two standard deviations above the mean (0) in the latent trait.

Descriptive analysis of the scale

With the factor structure shown, a mean score of 29.14 ($SD = 5.65$) was found for the global 6-PAQ score. For Factor 1, labelled Open, the mean score was 9.52 ($SD = 2.51$), for Factor 2, defined as Aware, the mean score was 10.80 ($SD = 2.57$), and for Factor 3, defined as Active, the mean score was 8.80 ($SD = 2.08$). The first-order factors had the following mean scores: 4.70 ($SD = 1.41$) on Acceptance; 4.80 ($SD = 1.51$) on Defusion; 4.32 ($SD = 1.20$) on Being present; 6.41 ($SD = 1.80$) on Self-as-context; 3.86 ($DT = 1.10$) on Values; and 4.93 ($SD = 1.37$) on Committed Actions.

Table 4 shows the mean scores for the global 6-PAQ and each of the second-order factors by sociodemographic variables. Statistically significant differences were found for these variables in the Open factor related to children's ages ($F = 3.93$; $p = .009$), such that parents with three-to-seven-year-old children had higher scores ($M = 9.80$; $SD = 2.48$) with a small effect size than parents with children over 11 years old ($d = 0.38$).

Evidence of validity related to other variables

Pearson's correlations between scores on factors and the global 6-PAQ score were calculated, where all the 6-PAQ second-order factors were correlated with each other and with the global scale score. A positive correlation was found for all the second-order factors with the first-order factors. There were also correlations between the second-order factors, except for the Being present scale with Acceptance and Committed action with Defusion and Being present (see Table 5).

In addition, the analysis was performed with other variables in related constructs in which we found that the global score and its factors were statistically significantly correlated positively with the AAQ=II score. On Distraction actions and Thought suppression, and on Anxiety symptomatology, statistically significant positive correlations were found with the Open and Aware factors. No correlations with the depression measures were found. Finally, statistically significant negative correlations were found with Life satisfaction (Table 5).

Discussion

The objective of this study was to validate a questionnaire for evaluating parental psychological flexibility in a Spanish population, specifically, in fathers and mothers with at least one child aged three to sixteen. The Parental Acceptance Questionnaire (6-PAQ; Greene et al., 2015) is an instrument

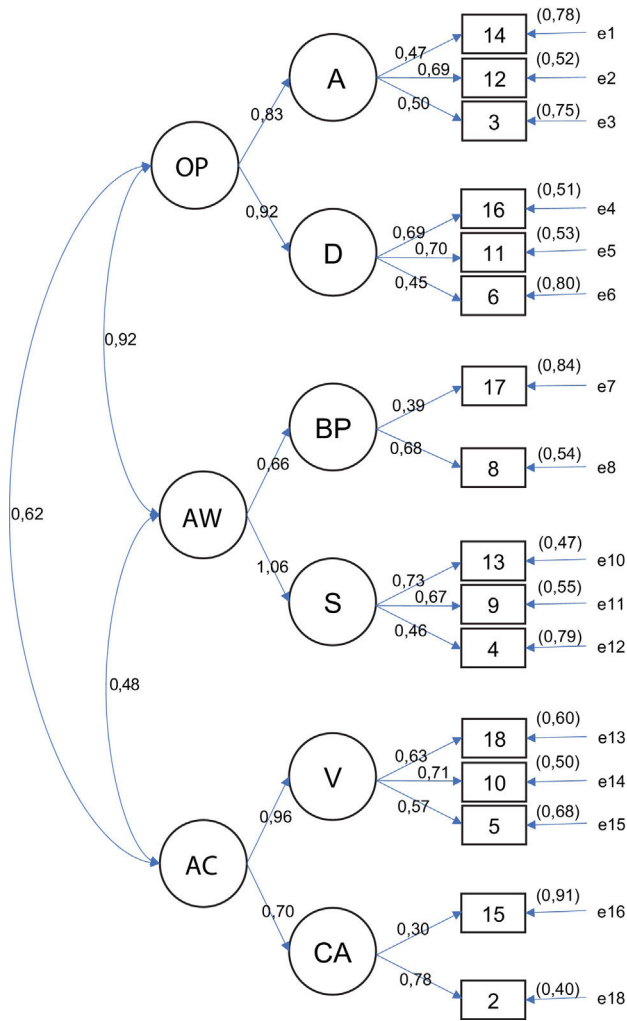

Figure 1 Confirmatory factor analysis model.

Note. Rectangles represent the observed variables (items), circles represent the variables of latent constructs and "e" represent the residual variances. The relationship scores between observed and latent variables represent the standardized factor loads. The scores between constructs are covariances. In brackets the variance of the items. All values are significant for $p < 0.001$. OP: Open; AW: Aware; AC: Active; A: Acceptance; D: Defusion; BP: Be present; S: self as context; V: Values; CA: Committed actions.

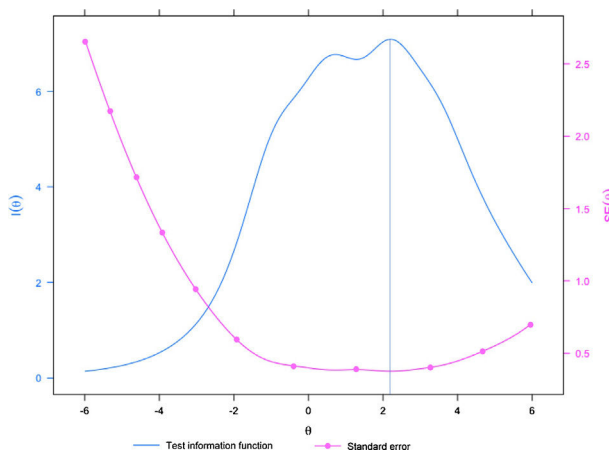

Figure 2 Test information function and standard error curve of 6PAQ with 16 items.

Note. $I(\theta)$ = Total score of test information function in left axis. $SE(\theta)$ = Score of standard error in right axis. θ = Test score.

Table 4 Análisis descriptivo de la puntuación total del 6-PAQ y sus factores según características sociodemográficas.

		<i>n</i>	%	Open	Aware	Active	Total 6-PAQ
Age	< 30	23	5.4	9.17 (2.33)	10.6 (2.81)	8.68 (2.81)	28.45 (6.49)
	30-34	59	13.8	9.85 (2.52)	10.9 (2.46)	8.73 (2.19)	29.49 (5.54)
	35-39	151	35.4	9.57 (2.49)	10.87 (2.73)	8.73 (2.03)	29.17 (5.74)
	40-45	134	31.4	9.30 (2.47)	10.67 (2.47)	8.8 (1.9)	28.78 (5.59)
	45 <	59	13.8	9.66 (2.76)	10.92 (2.27)	9.22 (1.81)	29.8 (5.15)
Education level	Primary	59	13.8	9.64 (2.82)	10.79 (2.83)	9.13 (2.56)	29.57 (6.74)
	Secondary	142	33.3	9.3 (2.34)	10.83 (2.42)	8.73 (2.03)	28.88 (5.01)
	Superior	216	50.7	9.56 (2.49)	10.75 (2.56)	8.7 (1.97)	29.02 (5.64)
Children age	< 3	37	8.6	8.91 (2.32)	10.48 (2.31)	8.62 (2.05)	28.02 (4.98)
	3 a 6	167	39.2	9.8 (2.48)	10.8 (2.55)	8.9 (2.08)	29.52 (5.54)
	7 a 11	133	31.2	9.77 (2.56)*	11.01 (2.74)	8.85 (2.16)	29.64 (6.01)
	11 >	86	20.1	8.86 (2.45)*	10.59 (2.46)	8.6 (2.01)	28.05 (5.48)

Note. * $p < .01$.

Table 5 Pearson's correlational analysis ($n = 274$).

	F1	F2	F3	Total	A	D	BP	S	CA	V
AAQ-II	.36**	.49**	.18**	.45**	.20**	.40**	.37**	.45**	.12*	.17**
ADTS	.35**	.39**	.09	.37**	.21**	.39**	.28**	.36**	.01	.12*
UIT	.33**	.44**	.15**	.41**	.18**	.37**	.31**	.41**	.09	.15**
WBSI	.36**	.43**	.13*	.41**	.20**	.39**	.31**	.41**	.06	.14*
SWL	-.34**	-.39**	-.12*	-.38**	-.21**	-.36**	-.24**	-.39**	-.06	-.12*
BAI	.28**	.36**	.08	.32**	.16**	.30**	.27**	.33**	.06	.07
BDI	-.03	-.06	-.03	-.05	-.05	-.00	-.01	-.07	-.07	.00
F2	.52**									
F3	.39**	.29**								
Total	.83**	.80**	.68**							
A	.83**	.34**	.39**	.67**						
D	.85**	.54**	.26**	.72**	.42**					
BP	.24**	.77**	.15**	.52**	.11	.29**				
S	.59**	.89**	.31**	.79**	.41**	.57**	.40**			
CA	.21**	.16**	.78**	.46**	.26**	.09	.08	.18**		
V	.41**	.30**	.86**	.65**	.37**	.32**	.17**	.32**	.36**	

Note. ** $p < .01$; * $p < .05$. F1: Open; F2: Aware; F3: Active; A: Acceptance; D: Defusion; BP: Being Present; S: Self-as-context; V: Values; AC: Committed actions; AAQII: Acceptance and Action Questionnaire; ADTS: Actions of distraction and thought suppression; ITU: Unwanted intrusive thoughts; WBSI: White Bear Suppression Inventory; SWL: Satisfaction with Life Scale; BAI: Beck Anxiety Inventory; BDI: Beck Depression Inventory.

for evaluating psychological flexibility through the six psychological flexibility processes in the conceptual Acceptance and Commitment Therapy (ACT) model. Thus, a high score on the global scale and on its subscales is associated with more psychological flexibility.

First, the confirmatory factor analysis of the original six-factor model proposed by the authors of the questionnaire showed good fit with the most important indices. However, the low internal consistency of some subscales and high correlation between the factors explored suggest that in this population a three-factor structure, as proposed previously by other authors, might be more feasible (Gootzeit, 2014; Harris, 2019; Hayes et al., 2012). Greene et al. (2015) found high correlations between these same subscales, but with a better result in internal consistency. The instrument shows good internal consistency for the global score, with a

Cronbach's alpha of .81 and a McDonald's omega coefficient of .86. The subscales had acceptable internal consistency with a Cronbach's alpha from 0.66 to 0.71 and McDonald's omega from .68 to .72. From this holistic and parsimonious view of the results, it is assumed that this last structure is the best fit for the Spanish population (Vowles, Sowden, & Ashworth, 2014). These results are consistent with those found when the six-factor model structure was explored in chronic pain, where a three-factor model had better fit.

These results show adequate psychometric properties but with a different factor structure, so the first hypothesis is partially confirmed.

Thus, the psychological flexibility model proposed is explained from a dimensional perspective as a behavioral continuum. The six processes are more closely related in

dyads leading to the factors, or response styles, posed. This psychological flexibility model proposed by Hayes et al. (2012) has also been explored by other authors (Harris, 2019). The first of the factors is defined as an open response style, with regard to a disposition to come into contact with direct experience in each moment, without judging it, with a full and flexible experience. An aware response style is based on focusing attention on the present moment, on the "here and now" voluntarily and flexibly, taking private events in perspective. Active response style is directed at actions that are framed in a context of values that make sense and motivate to change, leading to effective functioning in one's life. Thus, we define parental psychological flexibility as a response style, open to potentially distressful experiences (internal or external) related to their children, focused on "now", with acceptance and nonjudgmentally, taking private events in perspective, and acting with commitment to family values.

The mean scores showed cultural differences between the original version and the Spanish adaptation, both on the global scale and on its subscales. Specifically, the mean score on the global scale in the Spanish population was 33.70 ($SD = 5.90$), while in the sample in the original study it was 56.30 ($SD = 9.36$) (Greene et al., 2015), which indicates that the original sample showed more parental psychological inflexibility than the Spanish one. This difference was repeated in the subscales. There were also statistically significant differences in the Being open subscale between the parents who had children from three to eleven years old, in which they had greater difficulty in this disposition than parents of children from three to six. These results are in line with previous studies which have found higher scores in psychological inflexibility in parents with children under twelve years old (Brassell et al., 2016).

This study contributes an analysis of evidence of validity with related variables which the original validation study lacked. In this analysis we found that there is significant correlation between parental psychological inflexibility and experiential avoidance, the tendency to attempt to suppress or distract from unpleasant thoughts, dissatisfaction with life and higher anxiety levels. Difficulties in showing an open and accepting position, focused on the present and committed to parenting also showed correlations with avoidance, thought suppression and dissatisfaction with life. However, this correlation was not found with difficulties in taking a committed position and anxiety levels, while it was in the other two factors. Similar results have been found in studies relating inflexible parenting to higher levels of anxiety, stress and avoidance of negative thoughts (Emerson et al., 2019). In this sense, the second hypothesis of the study was partially confirmed, since no correlation was found with the depression variable.

This study had some limitations. First, it is a cross-sectional design which impedes interpreting causality. In addition, the sample was comprised mostly by women and the type of sampling employed hinders generalization of results. The questionnaire was self-applied and in different formats (paper and online) which could affect the variance of error. Neither were control variables employed for social desirability or response interference. Although the instrument is designed for application in clinical psychology, no

clinical sample was used in validation, so future studies should test the fit of the instrument in a clinical sample.

In conclusion, this study contributes the validation in a Spanish population of a reliable, valid instrument useful for measuring parental psychological flexibility, that is the skills for coming into contact with full awareness and with a disposition to openness to private events (emotions, thoughts, feelings, etc.) which could be unpleasant in interaction with and bringing up children, while acting or changing behavior in the direction of personal values. It also measures this aspect from three interrelated processes (being open, aware and active), subdivided in six processes (acceptance, being present, cognitive defusion, self-as-context, committed actions and values) which are usually applied in third-wave therapies, especially ACT. The instrument shows good fit indices in the factor structure. The results also show acceptable consistency indices for global score, and moderate for the subscales. As far as we know, this is the first instrument validated in a Spanish population which evaluates psychological flexibility in parents.

Funding

The present study has been carried out thanks to a predoctoral grant of the "Plan Propio de Investigación" of the University of Almeria, from which the first author is a beneficiary. This research is funded by the University of Almeria, the Ministry of Economy, Knowledge, Business and University of the Junta de Andalucía and the European Regional Development Fund (FEDER) (UAL18-HUM-D017-B1).

Appendix 1. Spanish version of *Parental Acceptance Questionnaire (6-PAQ)*

Lea cuidadosamente cada una de las siguientes afirmaciones. A continuación, elija la respuesta o la descripción que mejor describa sus pensamientos, sentimientos o estilo de interactuar con su hijo. Ninguna de las cosas que se dicen es verdadera ni falsa, sencillamente, usted estará más de acuerdo con unas cosas que con otras. Sus respuestas deben reflejar sus sentimientos y reacciones más consistentes que han estado presentes en los últimos meses.

1 = *Muy desacuerdo/nunca* 2 = *Desacuerdo/poco frecuente* 3 = *De acuerdo/con frecuencia* 4 = *Muy de acuerdo/siempre*

- 1 Soy constante en la manera de educar a mis hijos
- 2 Prefiero ceder en algo con mi hijo antes de que monte una escena en público
- 3 Me molesto si las cosas no salen a mi manera cuando me relaciono con mi hijo
- 4 Tengo claros mis valores relacionados con la forma de educar a mis hijos
- 5 Si alguien me critica como padre/madre, debe ser que soy un mal padre/madre
- 6 Siento que mi mente está en otro sitio cuando estoy jugando con mi hijo
- 7 Cuando mi hijo se comporta mal, me siento atrapado en mis emociones en lugar de tratar su comportamiento
- 8 Mis acciones como padre/madre son coherentes con mis valores

- 9 Tengo pensamientos negativos sobre mí mismo cuando mi hijo se porta mal
- 10 Es difícil iniciar o mantener una rutina porque no quiero enfrentarme a las reacciones de mi hijo
- 11 Cuando mi manera de educar no funciona como esperaba me siento un fracasado
- 12 Evito llevar a mi hijo a las tiendas por miedo a su comportamiento
- 13 Soy capaz de sacrificar mi comodidad por una disciplina efectiva
- 14 Soy un mal padre/madre cuando mi hijo se porta mal
- 15 Suelo planificar mi día y pensar en las cosas que tengo que hacer mientras paso tiempo con mi hijo
- 16 Tengo claros valores como padre/madre que guían mi interacción con mi hijo

References

- Beck, A. T., Epstein, N., Brown, G., & Steer, R. A. (1988). *An inventory for measuring clinical anxiety: Psychometric properties*. *Journal of Consulting and Clinical Psychology, 56*, 893–897.
- Beck, A. T., Steer, R. A., & Brown, G. K. (1996). *BDI-II. Beck Depression Inventory-Second Edition. Manual*. San Antonio, TX: The Psychological Corporation.
- Biglan, A., Gau, J. M., Jones, L. B., Hinds, E., Rusby, J. C., Cody, C., & Sprague, J. (2015). The role of experiential avoidance in the relationship between family conflict and depression among early adolescents. *Journal of Contextual Behavioral Science, 4*, 30–36. <http://dx.doi.org/10.1016/J.JCBS.2014.12.001>
- Bond, F. W., Hayes, S. C., Baer, R. A., Carpenter, K. M., Guenole, N., Orcutt, H. K., Waltz, T., & Zettle, R. D. (2011). Preliminary Psychometric Properties of the Acceptance and Action Questionnaire-II: A Revised Measure of Psychological Inflexibility and Experiential Avoidance. *Behavior Therapy, 42*, 676–688. <http://dx.doi.org/10.1016/j.beth.2011.03.007>
- Brassell, A. A., Rosenberg, E., Parent, J., Rough, J. N., Fondacaro, K., & Seehuus, M. (2016). Parent's psychological flexibility: Associations with parenting and child psychosocial well-being. *Journal of Contextual Behavioral Science, 5*, 111–120. <http://dx.doi.org/10.1016/J.JCBS.2016.03.001>
- Brown, F. L., Whittingham, K., & Sofronoff, K. (2015). *Parental Experiential Avoidance as a Potential Mechanism of Change in a Parenting Intervention for Parents of Children With Pediatric Acquired Brain Injury*. *Journal of Pediatric Psychology, 40*, 464–474.
- Brown, T. (2006). *Confirmatory factor analysis for applied research*. Nueva York, NY: Guilford Press.
- Burke, K., & Moore, S. (2015). Development of the Parental Psychological Flexibility Questionnaire. *Child Psychiatry y Human Development, 46*, 548–557. <http://dx.doi.org/10.1007/s10578-014-0495-x>
- Cheron, D. M., Ehrenreich, J. T., & Pincus, D. B. (2009). Assessment of Parental Experiential Avoidance in a Clinical Sample of Children with Anxiety Disorders. *Child Psychiatry and Human Development, 40*, 383–403. <http://dx.doi.org/10.1007/s10578-009-0135-z>
- Cohen, J. (1988). *Statistical power analysis for the behavioral sciences*. Nueva York, NY: Lawrence Erlbaum Associates.
- Diener, E., Emmons, R., Larsen, R. J., & Griffin, S. (1985). The Satisfaction with Life Scale. *Journal of Personality Assessment, 49*, 71–75. http://dx.doi.org/10.1207/s15327752jpa4901_13
- Emerson, L. M., Ogielka, C., & Rowse, G. (2019). The role of experiential avoidance and parental control in the association between parent and child anxiety. *Frontiers in Psychology, 10*(FEB) <http://dx.doi.org/10.3389/fpsyg.2019.00262>
- González Rodríguez, M., Avero Delgado, P., Rovella, A. T., & León, R. C. (2008). Structural Validity and Reliability of the Spanish Version of the White Bear Suppression Inventory (WBSI) in a Sample of the General Spanish Population. *The Spanish Journal of Psychology, 11*, 650–659. <http://dx.doi.org/10.1017/s1138741600004650>
- Gootzeit, J. <https://ir.uiowa.edu/etd/1325/>, 2014
- Greene, R. L., Field, C. E., Fargo, J. D., & Twohig, M. P. (2015). Development and validation of the parental acceptance questionnaire (6-PAQ). *Journal of Contextual Behavioral Science, 4*, 170–175. <http://dx.doi.org/10.1016/j.jcbs.2015.05.003>
- Hambleton, R. K. (2005). *Issues, designs, and technical guidelines for adapting tests into multiple languages and cultures*. In R. K. Hambleton, P. F. Merenda, & C. D. Spielberger (Eds.), *Adapting educational and psychological tests for cross-cultural assessment* (pp. 3–38). London: Psychology Press.
- Harris, R. (2019). *ACT Made Simple: An easy-to-read primer on acceptance and commitment therapy*. Oakland, CA: Nuw Harbinger.
- Hayes, S. C., Luoma, J. B., Bond, F. W., Masuda, A., & Lillis, J. (2006). Acceptance and Commitment Therapy: Model, processes and outcomes. *Behaviour Research and Therapy, 44*, 1–25. <http://dx.doi.org/10.1016/j.brat.2005.06.006>
- Hayes, S., Strosahl, K., & Wilson, K. (2012). *Acceptance and commitment therapy: The process and practice of mindful change*. Nueva York, NY: Guilford Press.
- Jackson, D. L., Gillaspay, J. A., & Purc-Stephenson, R. (2009). Reporting practices in confirmatory factor analysis: An overview and some recommendations. *Psychological Methods, 14*, 6–23. <http://dx.doi.org/10.1037/a0014694>
- Kashdan, T. B., & Rottenberg, J. (2010). Psychological flexibility as a fundamental aspect of health. *Clinical Psychology Review, 30*, 865–878. <http://dx.doi.org/10.1016/j.cpr.2010.03.001>
- Kuba, K., Weißflog, G., Götze, H., García-Torres, F., Mehnert, A., & Esser, P. (2019). *The relationship between acceptance, fatigue, and subjective cognitive impairment in hematologic cancer survivors*. *International Journal of Clinical and Health Psychology, 19*, 97–106.
- McDonald, R. P. (1999). *Test theory: A unified treatment*. Mahwah, NJ: Lawrence Erlbaum.
- Magán, I., Sanz, J., & García-Vera, M. P. (2008). Psychometric Properties of a Spanish Version of the Beck Anxiety Inventory (BAI) in General Population. *The Spanish Journal of Psychology, 11*, 626–640. <http://dx.doi.org/10.1017/s1138741600004637>
- Muñiz, J. (2018). *Introducción a la psicometría*. Madrid: Ediciones Pirámide.
- Muñiz, J., & Fonseca-Pedrero, E. (2019). Diez pasos para la construcción de un test. *Psicothema, 31*, 7–16. <http://dx.doi.org/10.7334/psicothema2018.291>
- Ong, C. W., Lee, E. B., Levin, M. E., & Twohig, M. P. (2019). A review of AAQ variants and other context-specific measures of psychological flexibility. *Journal of Contextual Behavioral Science, 12*, 329–346. <http://dx.doi.org/10.1016/J.JCBS.2019.02.007>
- Pagnini, F., Cavalera, C., Rovaris, M., Mendozzi, L., Molinari, E., Phillips, D., & Langer, E. (2019). Longitudinal associations between mindfulness and well-being in people with multiple sclerosis. *International Journal of Clinical and Health Psychology, 19*, 22–30. <http://dx.doi.org/10.1016/j.ijchp.2018.11.003>
- Ruiz, F. J., Langer Herrera, A. I., Luciano, C., Cangas, A. J., & Beltrán, I. (2013). Measuring experiential avoidance and psychological inflexibility: The Spanish version of the Acceptance and Action Questionnaire-II. *Psicothema, 25*, 123–129. <http://dx.doi.org/10.7334/psicothema2011.239>
- Sanz, J., Perdígón, A. L., & Vázquez, C. (2003). *Adaptación española del Inventario para la Depresión de Beck-II (BDI-II): 2. Propiedades psicométricas en población general*. *Clínica y Salud, 14*, 249–281.

- Vázquez, C., Duque, A., & Hervás, G. (2013). Satisfaction with life scale in a representative sample of Spanish adults: Validation and normative data. *Spanish Journal of Psychology*, *16*(e82), 1–15. <http://dx.doi.org/10.1017/sjp.2013.82>
- Vowles, K. E., Sowden, G., & Ashworth, J. (2014). A Comprehensive Examination of the Model Underlying Acceptance and Commitment Therapy for Chronic Pain. *Behavior Therapy*, *45*, 390–401. <http://dx.doi.org/10.1016/J.BETH.2013.12.009>
- Wersebe, H., Lieb, R., Meyer, A. H., Hofer, P., & Gloster, A. T. (2018). Relación entre estrés, bienestar y flexibilidad psicológica durante una intervención de autoayuda de Terapia de Aceptación y Compromiso. *International Journal of Clinical and Health Psychology*, *18*, 60–68. <http://dx.doi.org/10.1016/j.ijchp.2017.09.002>
- Wegner, D. M., & Zanakos, S. (1994). Chronic thought suppression. *Journal of Personality*, *62*, 615–640.
- Whittingham, K., & Coyne, L. W. (2019). *Acceptance and commitment therapy: The clinician's guide for supporting parents*. Londres: Academic Press.
- Williams, K. E., Ciarrochi, J., & Heaven, P. C. L. (2012). Inflexible Parents, Inflexible Kids: A 6-Year Longitudinal Study of Parenting Style and the Development of Psychological Flexibility in Adolescents. *Journal of Youth and Adolescence*, *41*, 1053–1066. <http://dx.doi.org/10.1007/s10964-012-9744-0>