



ORIGINAL

Removal of dyes by immobilization of *Trametes versicolor* in a solid-state micro-fermentation system



L.A. Diorio^{*,1}, D.M. Salvatierra Fréchou¹, L.N. Levin

University of Buenos Aires, Faculty of Exact and Natural Sciences, Department of Biodiversity and Experimental Biology, INMIBO-CONICET, Intendente Güiraldes 2160 - C1428EGA, Argentina

Received 19 December 2019; accepted 28 April 2020
Available online 30 June 2020

KEYWORDS

Bioreactor;
Solid-state
fermentation;
Decolorization;
Trametes versicolor;
Laccase

Abstract A novel bioreactor system (low cost and easily scaled-up) is presented for dye decolorization applying filamentous fungi. In this two-phase bioreactor, dyes were decolorized at 28 °C in a first phase by immobilized fungi in spherical cartridges prepared with a high-density plastic polyethylene mesh and filled with wheat bran as substrate for growth. In a second phase the capacity of the ligninolytic enzymes (laccase and Mn-peroxidase) present in the extracellular extracts from the solid residues was exploited for decolorization at 50 °C. Each sphere behaved as a small-scale bioreactor for cell-culture. This system allowed the decoupling of growth (sterile condition) and decolorization (non-sterile condition) stages. The ability to decolorize the azo dye xylidine and the triphenylmethane Malachite Green by two Argentinean strains of *Trametes versicolor* was evaluated. The highest decolorization rates were displayed by *T. versicolor* BAFC 2234. When both dyes were applied together in the bioreactor, after a first phase (100 min) 73.5% of Malachite Green and 40% of xylidine decolorization was attained, while at the end of the second phase (240 min) a 97% and 52% decolorization was observed. Laccase activity was detected in the decolorized solution, but no Mn-peroxidase activity. The easy change of the cartridges allows the continuous use of the bioreactor in the non-sterile decolorization of dye-containing effluents.

© 2020 Asociación Argentina de Microbiología. Published by Elsevier España, S.L.U. This is an open access article under the CC BY-NC-ND license (<http://creativecommons.org/licenses/by-nc-nd/4.0/>).

PALABRAS CLAVE

Biorreactor;
Fermentación en
estado sólido;
Decoloración;

Remoción de colorantes por *Trametes versicolor* inmovilizado en un sistema de microfermentación en estado sólido

Resumen Se presenta un novedoso sistema de biorreactor de dos fases, de bajo costo y fácil ampliación, para la decoloración de colorantes aplicando hongos filamentosos. Durante la primera fase, los colorantes estuvieron en contacto con los hongos inmovilizados en

* Corresponding author. Tel. +54 11 5285 8594.

E-mail address: luis.diorio@gmail.com (L.A. Diorio).

¹ These authors contributed equally to this work.

Trametes versicolor;
Lacasa

cartuchos esféricos preparados con una malla de polietileno plástico de alta densidad y rellenos con salvado de trigo como sustrato para el crecimiento a 28 °C. En una segunda fase, se explotó la capacidad de las enzimas ligninolíticas (lacasa y Mn-peroxidasa) presentes en los extractos de los residuos sólidos para la decoloración a 50 °C. Cada esfera se comportó como un biorreactor a pequeña escala. Este sistema permitió desacoplar las etapas de crecimiento en esterilidad de las de decoloración en condiciones no estériles. Se evaluó la capacidad de decolorar el tinte azoico xilidina y el trifenilmetánico verde de malaquita por dos cepas argentinas de *Trametes versicolor*. *T. versicolor* BAFC 2234 mostró las tasas de decoloración más altas. Cuando ambos colorantes se aplicaron juntos en el biorreactor, después de la primera fase (100 min) se alcanzó una decoloración del 73,5% para el verde de malaquita y del 40% para la xilidina, mientras que al final de la segunda fase (240 min) se observó una decoloración del 97 y 52%, respectivamente. Se detectó actividad lacasa en la solución decolorada, pero no actividad Mn-peroxidasa. El sistema mostró fácil operatividad de los cartuchos y permitió un uso continuo del biorreactor para la decoloración no estéril de efluentes coloreados.

© 2020 Asociación Argentina de Microbiología. Publicado por Elsevier España, S.L.U. Este es un artículo Open Access bajo la licencia CC BY-NC-ND (<http://creativecommons.org/licenses/by-nc-nd/4.0/>).

Introduction

Dyes are broadly used in the textile, food, pharmaceutical, cosmetic, printing and leather industries. Effluents containing 5-10% of dyestuffs are usually discharged into natural water bodies and may affect water transparency and gas solubility and cause severe environmental pollution because of their carcinogenicity and toxicity. Traditional technologies for dye treatment are not always effective or may not be environmentally friendly. This has encouraged the search for alternative technologies such as biodegradation with fungi^{9,20}. Fungal biomass is used as a sorbent and/or producer of enzymes involved in biodegradation/biotransformation. White-rot fungi and their nonspecific oxidative ligninolytic enzymes (laccases and peroxidases) have been reported to be responsible for the decolorization and detoxification of different synthetic dyes. Thus, their use can provide alternative methods to replace or complement the current technologies for dye removal^{8,12,21,26,28,37}. The major drawback of using an enzyme preparation is that once the enzymes become inactivated, activity decreases. However, with whole cell cultures, the enzymes could be continually replenished. Furthermore, growing biomass could supply other enzymes and mediators for dye transformation.

The immobilization of white-rot fungi has been successfully applied to the treatment of dye-containing effluents^{15,20,33}. This technique allows to use the microbial cells repeatedly and continuously and facilitates separation of cells from the liquid reaction medium. Immobilized cultures tend to show a higher level of enzymatic activity and more resilience to environmental perturbations such as shear damage and pH/toxic shock²⁶. Moreover, it was found in experiments on dye degradation by white-rot fungi that the transport of the dye through the matrix facilitates constant biodegradation by maintaining a low dye concentration near the fungus^{17,22}. When high pollutant concentrations are treated, this system will keep the microorganism viable for a longer period. Nevertheless, there are few designs

available in the literature for bioreactors operating in solid-state fermentation (SSF) conditions, mainly due to the difficulty in the control of parameters such as pH, temperature, aeration and oxygen transfer, moisture and agitation. These disadvantages have promoted the necessity of developing new bioreactor configurations^{10,19,33}.

Azo dyes dominate the worldwide market of dyestuffs²⁶. The biggest problem with their enzymatic cleavage under anaerobic conditions is the formation of toxic amines, many of which are mutagenic and/or carcinogenic. Malachite green is a widely used, though highly toxic triphenylmethane dye, which is employed in aquaculture as a parasiticide/fungicide and in the industrial dyeing of fabrics, colored ceramics and paper¹⁸. Laccases involved in aerobic azo dye decolorization by white-rot fungi repeatedly proved to be effective for their detoxification^{2,14}. Malachite Green was also detoxified by *Pleurotus florida*²⁹, and *Ganoderma* sp.³¹ laccases.

In this work, a novel bioreactor system is presented for dye decolorization applying ligninolytic fungi. The design is based on Diorio et al.'s⁶ two-phase bioreactor, where dyes were decolorized by immobilized fungi in the first phase and in a second phase by their extracellular extracts, without contact between the dye and the fungus. In that work a cylindrical cartridge built with stainless steel twilled weave was employed. In the present work spherical cartridges were prepared with a high-density plastic polyethylene mesh and filled with wheat bran as support material for fungal growth. This is a low cost lignocellulosic agro-residue that offers the nutrients needed for fungal growth and ligninolytic enzyme production³⁴. SSF which proceeds in the absence or near absence of free liquid, employing inert or natural substrates (especially agro-industrial materials) as solid supports, is particularly appropriate to produce enzymes by filamentous fungi since it reproduces the conditions under which these fungi grow in nature⁷.

The ability to decolorize xylidine and malachite green by *Trametes versicolor* BAFC 2234 and *T. versicolor* (syn. *Coriolus versicolor* f. *antarcticus*, BAFC 266) was evaluated in this

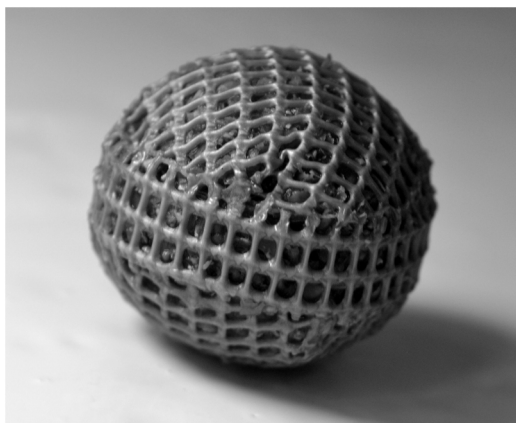

Figure 1 Spherical cartridge of high-density plastic polyethylene mesh filled with wheat bran.

novel bioreactor system. *T. versicolor* BAFC 266 was selected among 58 basidiomycetes from Argentina for its capacity to decolorize Azure B and Poly R-478 in solid medium¹⁷. Its culture filtrates with laccase and manganese peroxidase (MnP) ligninolytic activities proved capable of decolorizing various dyes with different chemical structures¹⁶. *T. versicolor* BAFC 2234 was identified in a screening of Argentinean white-rot fungi tested for their tolerance toward high concentrations of different phenolic compounds. This fungus immobilized on natural plant sponge could remove up to 15mM phenol and decrease the phytotoxicity of treated samples⁵.

Materials and methods

Microorganisms

T. versicolor BAFC 2234 (Culture Collection of the Department of Biological Sciences, Faculty of Exact and Natural Sciences, University of Buenos Aires) and *T. versicolor* (BAFC 266) were maintained at 4°C on malt-extract agar slants (1.3% malt extract, 1% glucose, 2% agar).

Cartridge preparation

Spherical cartridges were prepared with a high-density plastic polyethylene mesh (mesh size: 1.5 mm x 1.5 mm) (Fig. 1). Squares of 5 cm x 5 cm were heat unstiffened and molded over solid glass balls to obtain hemispheres that were assembled with a strip of mesh of 8 cm x 1 cm, heat sealing the ends. Before closing the spheres, they were packed with dried wheat bran up to a concentration of 0.159 g/cm³. The diameter of the filled spheres was 2.7 ± 0.05 cm. The spheres were moisturized by introducing them slowly into distilled water to avoid the formation of bubbles. They were hydrated overnight and drained 1 h up to a moisture content of 73%, and then autoclaved at 121°C 20 min. The inoculum consisted of two 0.5 cm² agar plugs placed in opposite sides of the spheres, cut out from the margin of 5-day old colonies grown on malt-extract/agar medium (with 1.8% agar to facilitate inoculum adherence). The inoculated spheres were

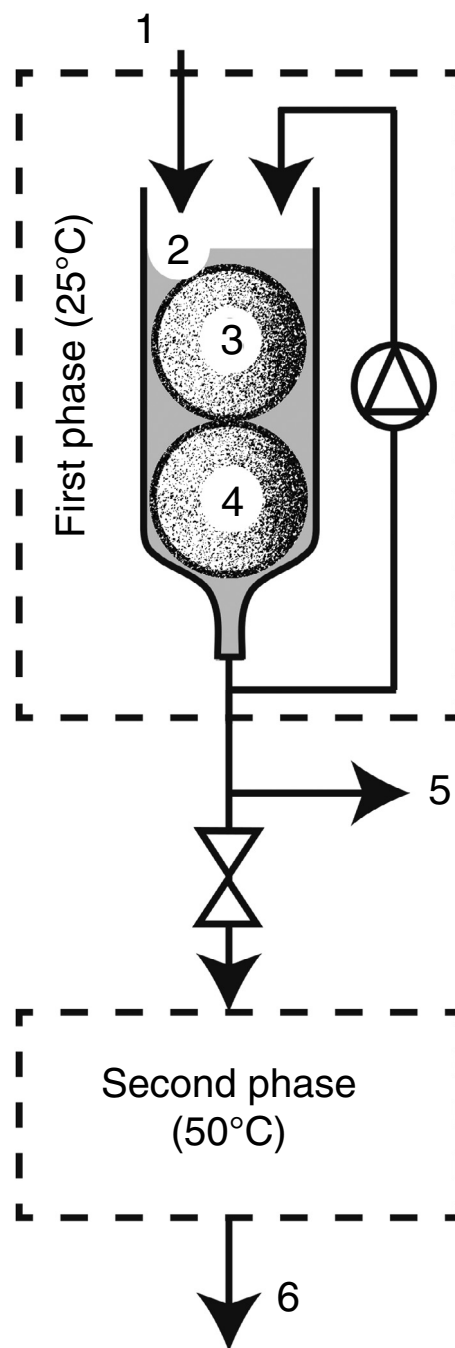

Figure 2 Diagram of the bioreactor employed: dye solution inlet (1), dye solution level (2), fungus and support-substrate (3, 4), sampling port (5), stainless steel coil (6), treated dye outlet (7).

incubated at 28°C in 16 cm Petri plates with a beaker of water inside and Parafilm® sealed to prevent moisture loss.

Bioreactor configuration

Bioreactor configuration (Fig. 2) was based on the two-phase bioreactor described by Diorio et al.⁶. In this work, first phase configuration consisted of a glass column of 15 cm height and 3 cm diameter that was kept in an incubator at

28 °C. All the elements of the device were autoclaved at 121 °C for 20 min. Eighteen-days pre-grown *T. versicolor* cartridges (1, 2, 3 or 4) were introduced into the glass column, and it was overflowed respectively with 17, 30, 43 or 50 ml of an aqueous non-sterile solution of the dye (20 μ M). Then it was homogenized with a flow rate of 1 ml/min throughout the decolorization process. Samples were taken from the base of the bioreactor to determine pH, enzymatic activities and decolorization. Controls were made with non-inoculated cartridges. Second phase configuration: after a period of either 25, 40, 100 or 110 min, where the extract was subjected to decolorization in the first phase, it was overturned to the second phase that consisted of a stainless steel coil of 6.35 mm diameter and a total length of 6.65 mm, placed in a thermostatic bath at 50 °C. Samples were taken at the termination of the coil (at the end of the first and second phases) and they were used for pH determination, enzymatic activities and assessment of the decolorization rate.

Analytical determinations

Estimation of fungal growth: the fungus growth inside the cartridge was estimated by measuring its chitin content. The chitin content of dried samples and mycelium from malt-extract liquid cultures was determined by measuring N-acetylglucosamine (NAGA) released from chitin after hydrolysis with 6N HCl²³. The mycelium that covered the spheres was removed with a scalpel to estimate the dry weight of the biofilm. Weight losses were determined based on the initial and final dry weights, drying the content of each sphere to constant weight at 80 °C. Dried samples were ground in a mortar and stored until they were used for chitin determination. Polyethylene meshes were washed, dried and weighed as well to determine potential damage. For enzyme extraction, crude extracts were obtained by adding 12 ml of distilled water to 2 g wet solid, stirring for 20 min at 120 rpm, followed by filtration and centrifugation. Enzyme activities were also determined in aqueous extracts obtained by stirring 1 sphere in 30 ml of distilled water for 20 min. The extracts were stored at -20 °C until needed. Laccase was evaluated using 5 mM 2,2-azino-bis (3-ethylbenzthiazoline-6-sulfonic acid) as substrate in 0.1 M sodium acetate buffer (pH 3.6) at 420 nm ($\epsilon_{420} = 1/36 \text{ mM cm}$)¹⁷. MnP was determined using 0.01% phenol red as substrate in 50 mM succinate buffer (pH 4.5) at 610 nm ($\epsilon_{610} = 1/36 \text{ mM cm}$)¹⁷. All enzyme activities were measured at 30 °C and expressed in units (U) defined as the amount of enzyme required to produce 1 μ mol of product per min per ml of aqueous extract or g of dry residue (substrate plus mycelium) extracted. Reducing sugars were quantified by the Somogyi-Nelson method³², using glucose as standard.

Decolorization assays

Decolorization capacity of aqueous solutions of the azoic dyes xylidine and Congo Red, the triphenylmethane-type dyes Malachite Green and Gentian Violet, the anthraquinonic Remazol Brilliant Blue R (RBBR) and the indigoid Indigo Carmine, was assessed measuring the decrease of dye absorbance at their maximum visible

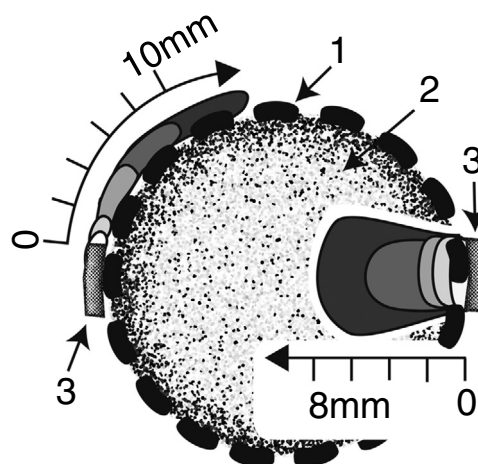

Figure 3 Fungal colonization of the spherical cartridge. 1, plastic polyethylene mesh; 2, wheat bran; 3, inoculum. The areas of different shades of gray indicate 1 (white) to 5 (dark gray) days of growth.

wavelength, 505, 490, 615, 590, 590 and 609 nm respectively. Decolorization was expressed as percentage over the initial values⁸. Samples obtained from the bioreactor solution were evaluated spectrophotometrically after being appropriately diluted. The remnant dye retained in the cartridge after the decolorization processes was extracted with ethanol-water (1:1) for 24 h.

Statistical analysis

The data presented are the average of the results of three replicates with a standard error of less than 5%. Analysis of variance was tested by the software Minitab v.13.0. The significant differences between treatments were compared by Tukey's multiple comparison tests at 5% level of probability.

Chemicals

Malachite Green and Congo Red were provided by Mallinckrodt (Phillipsburg, N.J., USA) and Indigo Carmine by ICN (Costa Mesa, California, USA). All other chemicals were from Sigma (St. Louis, Mo., USA).

Results and discussion

Growth of *T. versicolor* in the spherical cartridges

A novel bioreactor system was developed for dye decolorization applying ligninolytic basidiomycetes, based on Diorio et al.'s⁶ two-phase bioreactor, where dyes were decolorized by immobilized fungi in the first phase and by their extracellular extracts in a second phase. Each sphere behaved as a small-scale bioreactor for cell-culture. Figure 3 depicts fungal colonization of the spherical cartridges. Growth was monitored by measuring the chitin content in the dried substrate. The ratio of glucosamine to dry mass in pure mycelium was determined by culturing *T. versicolor* in malt-extract liquid medium, and was used to estimate fungal

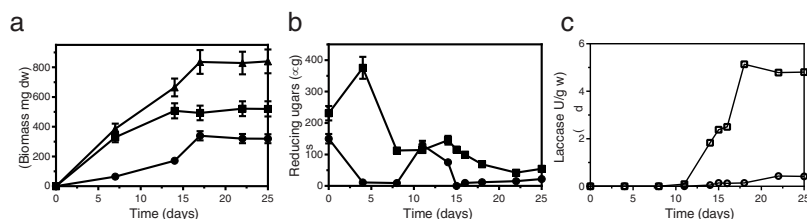

Figure 4 Time course of growth and laccase production by *T. versicolor* BAFC 266 growing in the spherical cartridge. (a) Biofilm biomass (●), invasive mycelium (■) and total biomass (▲). (b) Glucose consumption inside the cartridge (■), and in the biofilm zone (●). (c) Laccase production inside the cartridge (□), and in the biofilm zone (○). Error bars denote SEM.

biomass in the cartridges. *T. versicolor* (BAFC 266) mycelium not only totally invaded the substrate contained in the spherical cartridges but completely covered the surrounding mesh forming a biofilm after only 7 days as well. During the first 7 days most of the fungal biomass consisted of invasive mycelium (83%) but biomass of the fungal biofilm increased, representing 41% of the total at day 18 (Fig. 4a). Possibly the spherical shape of the cartridge allowed a better development of the biofilm, and permitted a more delimited separation between this micro reactor and its surrounding exterior. The reducing sugars measured inside the spheres attained a maximum on the 4th day of incubation, probably released by fungal hydrolytic enzymes (not determined in this work) but decreased afterwards supporting fungal growth (Fig. 4b). Temperature increased inside the cartridges (0.8 ± 0.10 °C after 16–22 days of fungal incubation), and pH varied from initial values around 5.0 up to 6.3 at the end of cultivation. Laccase activity was detected inside the cartridges from day 14 of incubation (Fig. 4c), in coincidence with a substantial decrease in the available reducing sugars (highest titers measured on day 18: 5.3 U/g). MnP activity was detected inside the cartridges from day 16 on (approx. 0.18 U/g, data not shown). Very low titers of laccase and MnP were measured in the biofilm as well. The differences in temperature and pH between the interior of the spheres and their exterior, internal accumulation of reducing sugars and ligninolytic enzymes, and the absence of dye adsorption, demonstrates their functionality. Very few articles have considered the effects of morphology on the degree of removal of recalcitrant pollutants such as dyes.³⁰ Bermek et al.³ reported that fungal growth as dispersed filaments can increase the viscosity of the medium (low oxygen levels), limiting mass transfer and causing lower ligninolytic enzyme production. The support material for fungal growth was wheat bran. It is a stable low-cost lignocellulosic agro-residue considering its particle size, water content and physicochemical properties. High titers of laccase production were detected when growing *T. versicolor* on wheat bran³⁴.

Ligninolytic activity and decolorization of the aqueous extracts in the bioreactor

One up to five spheres with *T. versicolor* (BAFC 266) grown for 18 d in wheat bran were introduced in the bioreactor. The activities of laccase and MnP retained in the interior of the solid medium were 4.7 and 43.7 times higher respectively than those detected in the aqueous extracts, showing

not only abundant exoenzyme production by *T. versicolor* (BAFC 266) under the experimental conditions assayed, but also a significant accumulation inside the bran spheres grown with the fungus, which would therefore allow their reutilization. The bioreactor was flooded with 17, 30, 43 or 50 ml respectively of an aqueous non-sterile solution of Malachite Green (20 μM). After 40 min decolorization reached 32–35%, the best values were attained with 2 spheres. The fungus remained well attached to the carrier during the whole experiment and the medium stayed totally clear. Total decolorization was approx. 95% after 240 min of Malachite Green retention. Ligninolytic activities were evaluated in the decolorized solution (respectively among 0.66–0.78 U/ml laccase and 0.09–0.13 U/ml MnP during all the incubation period). Laccase highest values were detected when 2 spheres were applied. The dye was rapidly removed from the medium by physical adsorption, but was later eliminated both from the solution and the surface of the carriers, as a consequence of enzymatic degradation, and Malachite Green retained (adsorbed) in the spheres was not detected, at the end of the assay. Similar results were obtained by Aretxaga et al.¹ when comparing dye adsorption by dead pellets of *T. versicolor* and dye removal by enzymatic degradation. Likewise, sorption accounted for less than 3% of dye removal by ligninolytic (dye-decolorizing) cultures of *Pycnoporus sanguineus*²⁴.

The bioreactor filled with two bran spheres colonized by *T. versicolor* BAFC 266 was also applied to the decolorization of several dyes with different chemical structures. This fungus was able to decolorize 50% of Gentian Violet, Congo Red, RBBR and Indigo Carmine (each 20 μM) in the bioreactor after 53, 118, 141 and 14 min respectively. The pH of the extracts did not vary throughout the entire experience, thus decolorization cannot be attributed to pH-dependent color variation²⁵. The respective percentages of decolorization after 240 min were 70, 54, 54 and 80%. Dye decolorization of Malachite Green, xyloidine or a mixture of both dyes (each 20 μM) was assayed as well. After 240 min approx. 15% xyloidine degradation was detected (Fig. 5a). Laccase and MnP activities evaluated in the xyloidine decolorized solution after 90 min were lower than those measured in the presence of Malachite Green (0.22 U/ml laccase and 0.02 U/ml MnP). In a previous work, submerged cultures of *T. versicolor* (BAFC 266), which only displayed laccase activity, decolorized 28% of xyloidine (24 mg/l), 30% of Poly-R 478 (75 mg/l), 43% of Remazol Brilliant Blue R (9 mg/l), 88% of Malachite Green (6 mg/l) and 98% of Indigo Carmine (23 mg/l), in 1 h.¹⁷ The efficiency of Malachite Green decolorization was not affected by increasing the dye up to 100 μM⁶. *T. versicolor*

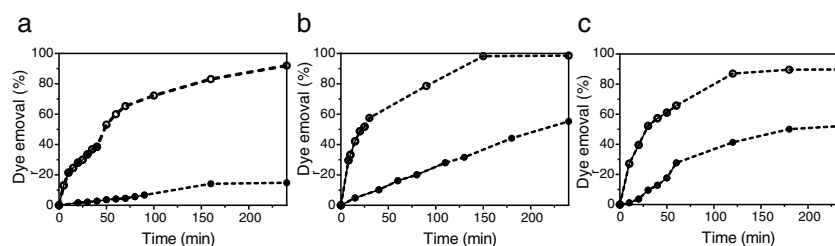

Figure 5 Profile of xylidine (20 μ M) (●) and Malachite Green (20 μ M) (○) dye removal attained by solid-state cultures of *T. versicolor* BAFC 266 (a) and *T. versicolor* BAFC 2234 (b) when the dyes were applied individually in the bioreactor. (c) xylidine and Malachite Green dye removal by *T. versicolor* BAFC 2234 when the dyes were applied together. First phase (—●—; —○—) and second phase (---●---; ---○---).

(BAFC 2234) grown for 18 d in two bran spheres was also evaluated in the bioreactor. Malachite Green decolorization rates were higher than those attained by *T. versicolor* (BAFC 266) not only during the first phase in the bioreactor but also in the second one: 52% decolorization was registered after 25 min and 98.2% after 150 min (Fig. 5b). Laccase but no MnP activity was detected in the decolorized solution (0.09 U/ml), as previously recorded during Malachite Green decolorization in liquid cultures of other *Trametes* species¹¹. *T. versicolor* (BAFC 2234) could also decolorize 28% of xylidine after 110 min and 55.3% after 240 min. *T. versicolor* BAFC 2234 xylidine decolorization rate (2.9 mg/l h) resembles the previously described for other strain of the same species in relation to different azo dyes (3 mg/l h)³⁵. Both lignolytic activities tested were detected in the decolorized solution after 110 min (respectively 0.22 U/ml laccase and 0.12 U/ml MnP). When Malachite Green and xylidine were applied together in the bioreactor using *T. versicolor* BAFC 2234 (Fig. 5c), after a first phase that lasted 100 min 73.5% of Malachite Green and 40% of xylidine were decolorized. At the end of the second phase (240 min) 96.6% of Malachite Green and 51.7% of xylidine were decolorized. Laccase activity was detected in the decolorized solution (0.16 U/ml), but no MnP activity. In a preceding work when cylindrical cartridges filled with wheat bran were used to support fungal growth, 4 up to 20% of Malachite Green was retained inside the cartridges⁶. In this work dye adsorption was not noticed at the end of the assay. The spherical design might allow a better development of the biofilm surrounding the cartridge and impeded dye adsorption by the substrate.

Previous studies have shown that many enzymes are involved in Malachite Green decolorization, and that these enzymes are often species-specific; however, the main enzymes responsible for Malachite Green decolorization and detoxification by *Pseudomonas* bacteria, and by the filamentous fungi *Penicillium pinophilum* and *Myrothecium roridum*, proved to be laccase and malachite green-reductase¹¹. Low-molecular-weight factors might be involved in dye decolorization as well³⁵. Mycelial biomass may supply other intracellular or mycelial-bound enzymes, or other compounds that favor decolorization. Significant differences in the ability to decolorize Malachite Green among strains of *Trametes* were previously detected, but in most of the studied strains there was a correlation between laccase production and decolorization capacity.⁴

Malachite Green decolorization by *T. versicolor* (BAFC 266)⁶ was accompanied by detoxification. Co-cultivation of laccase-producing strains is a natural way to induce laccase production, in the form of either yield increase or induction of new isozymes. Microbial interactions with laccase inducing effects vary with the strain, but the structure of inducing metabolites and the mechanism involved remain basically unknown.³⁶ Co-cultivation of *Ganoderma lucidum* and *T. versicolor* resulted in a noticeable increase in laccase activity along with more efficient decolorization and detoxification of Malachite Green¹³. In the present work, the bioreactor was alternatively filled with two bran spheres, each with one of *T. versicolor* isolates. Nevertheless, similar results were obtained; 89.8% of Malachite Green and 52.4% of xylidine were decolorized after 4 h (data not shown).

Fungal dye decolorization under non-sterile conditions has been scarcely investigated up till now^{27,30}. The application of white-rot fungi in continuous bioreactors for dye wastewater treatment has been so far hindered by difficulties such as excessive growth of fungi causing reactor-clogging, bacterial contamination inhibiting fungal decolorization, and loss of extracellular enzymes and mediators essential for dye degradation with treated effluents³⁰. Nevertheless, this system allows decoupling of growth (sterile condition) and decolorization (non-sterile condition) stages.

In conclusion, a novel bioreactor system (low cost, eco-friendly, and easily scaled-up) is presented for dye decolorization applying lignolytic basidiomycetes. In this two-phase bioreactor, dyes were decolorized in the first phase by fungi immobilized in spherical plastic polyethylene mesh cartridges filled with wheat bran, and in a second phase by their extracellular extracts. The change of the cartridges is easy and quick, allowing a continuous use of the bioreactor in the decolorization process. Moreover, they can be used as sources of laccase for additional applications. Immobilized cell systems make easy to separate cells from the liquid medium, which simplifies subsequent downstream processes. The white-rot fungus *T. versicolor* BAFC 2234 immobilized in this bioreactor decolorized the recalcitrant dyes xylidine and Malachite Green with high efficiency. In addition, no operational problems were detected during cultivation. Based on these results, this system may have good prospects for application in industrial wastewater treatment.

Financial support

PIP11220170100283 and UBACYT 2020020170100163.

Conflict of interest

The authors declare that they have no conflicts of interest.

Acknowledgements

To Consejo Nacional de Investigaciones Científicas y Técnicas (CONICET and Universidad de Buenos Aires (UBA), Argentina, for financial support.

References

- Aretxaga A, Romero S, Sarra M, Vicent T. Adsorption step in the biological degradation of a textile dye. *Biotechnol Prog*. 2001;17:664–8.
- Benzina O, Daassi D, Zouari-Mechichi H, Frikha F, Woodward S, Belbahri L, Rodriguez-Couto S, Mechichi T. Decolorization and detoxification of two textile industry effluents by the laccase/1-hydroxybenzotriazole system. *Environ Sci Pollut Res Int*. 2013;20:5177–87.
- Bermek H, Güseren I, Li K, Jung H, Tamerler C. The effect of fungal morphology on ligninolytic enzyme production by a recently isolated wood degrading fungus *Trichophyton rubrum* LSK-27. *World J Microbiol Biotechnol*. 2004;20:345–9.
- Borchert M, Libra JA. Decolorization of reactive dyes by the white rot fungus *Trametes versicolor* in sequencing batch reactors. *Biotechnol Bioeng*. 2001;75:313–21.
- Carabajal M, Perullini M, Jobbágy M, Ullrich R, Hofrichter M, Levin L. Removal of phenol by immobilization of *Trametes versicolor* in silica-alginate-fungus biocomposites and loofa sponge. Contribution of ligninolytic enzymes to the process. *CLEAN*. 2016;44:180–8.
- Diorio LA, Mercuri AA, Nahabedian DE, Forchiassin F. Development of bioreactor system for the decolorization of dyes by *Coriolus versicolor* f. *antarcticus*. *Chemosphere*. 2008;72:150–6.
- Forootanfar H, Faramarzi MA. Insights into laccase producing organisms, fermentation states, purification strategies, and biotechnological applications. *Biotechnol Prog*. 2015;31:1443–63.
- Grassi E, Scodeller P, Filiel N, Carballo R, Levin L. Potential of *Trametes trogii* culture fluids and its purified laccase for the decolorization of different types of recalcitrant dyes without the addition of redox mediators. *Int Biodeterior Biodegradation*. 2011;65:635–43.
- Imran M, Crowley DE, Khalid A, Hussain S, Mumtaz MW, Arshad M. Microbial biotechnology for decolorization of textile wastewaters. *Rev Environ Sci Biotechnol*. 2015;14:73–92.
- Jaramillo AC, Cobas M, Hormaza A, Sanroman MA. Degradation of adsorbed azo dye by solid-state fermentation: Improvement of culture conditions, a kinetic study, and rotating drum bioreactor performance. *Water Air Soil Pollut*. 2017;228:205–12.
- Kalyani DC, Telke AA, Surwase SN, Jadhav SB, Lee JK, Jadhav JP. Effectual decolorization and detoxification of triphenylmethane dye malachite green (MG) by *Pseudomonas aeruginosa* NCIM 2074 and its enzyme system. *Clean Technol Environ Policy*. 2012;14:989–1001.
- Katheresan V, Kansedo J, Lau SY. Efficiency of various recent wastewater dye removal methods: a review. *J Environ Chem Eng*. 2018;6:4676–97.
- Kuhar F, Castiglia V, Levin L. Enhancement of laccase production and Malachite Green decolorization by co-culturing *Ganoderma lucidum* and *Trametes versicolor* in solid-state fermentation. *Int Biodeterior Biodegradation*. 2015;104:238–43.
- Legerská B, Chmelová D, Ondrejovič M. Decolourization and detoxification of monoazo dyes by laccase from the white-rot fungus *Trametes versicolor*. *J Biotechnol*. 2018;285:84–90.
- Lellis B, Fávoro-Polonio CZ, Pamphile JA, Polonio JC. Effects of textile dyes on health and the environment and bioremediation potential of living organisms. *Biotechnol Res Innov*. 2019;3:275–90.
- Levin L, Malignani E, Ramos AM. Effect of nitrogen sources and vitamins on ligninolytic enzyme production by some white-rot fungi. Dye decolorization by selected culture filtrates. *Bioresour Technol*. 2010;101:4554–63.
- Levin L, Papinutti L, Forchiassin F. Evaluation of Argentinean white rot fungi for their ability to produce lignin-modifying enzymes and decolorize industrial dyes. *Bioresour Technol*. 2004;94:169–76.
- Maalej-Kammoun M, Zouari-Mechichi H, Belbahri L, Woodward S, Mechichi M. Malachite Green decolorization and detoxification by the laccase from a newly isolated strain of *Trametes* sp. *Int Biodeterior Biodegradation*. 2009;63:600–6.
- Manan MA, Webb C. Design aspects of solid-state fermentation as applied to microbial bioprocessing. *J Appl Biotechnol Bioeng*. 2017;4:511–32.
- Mir-Tutusa JA, Baccar R, Caminal G, Sarrà M. Can white-rot fungi be a real wastewater treatment alternative for organic micropollutants removal? A review. *Water Res*. 2018;138:137–51.
- Moreira-Neto SL, Mussatto SI, Machado KMG, Milagres AM. Decolorization of salt-alkaline effluent with industrial reactive dyes by laccase-producing basidiomycetes strains. *Lett Appl Microbiol*. 2013;56:283–90.
- Perullini M, Jobbágy M, Mousa N, Forchiassin F, Bilmes SA. Silica alginate-fungi biocomposites for remediation of polluted water. *J Mater Chem*. 2010;20:6479–83.
- Plassard CS, Mousain DG, Salsac LE. Estimation of mycelial growth of basidiomycetes by means of chitin determination. *Phytochemistry*. 1982;21:345–8.
- Pointing SB, Vrijmoed LLP. Decolorization of azo and triphenylmethane dyes by *Pycnoporus sanguineus* producing laccase as the sole phenoloxidase. *World J Microbiol Biotechnol*. 2000;16:317–8.
- Rao CV, Giri AS, Goud VV, Golder AK. Studies on pH-dependent color variation and decomposition mechanism of Brilliant Green dye in Fenton reaction. *Int J Ind Chem*. 2016;7:71–80.
- Rodríguez-Couto S. Dye removal by immobilized fungi. *Biotechnol Adv*. 2009;27:227–35.
- Rodríguez-Couto S. Treatment of textile wastewater by white-rot fungi: still a faraway reality? *TLIST*. 2013;2:113–9.
- Rodríguez-Couto S. Industrial an environmental applications of white-rot fungi. *Mycosphere*. 2017;8:456–66.
- Sathishkumar P, Palvannan T, Murugesan K, Kamala-Kannan S. Detoxification of Malachite Green by *Pleurotus florida* laccase produced under solid-state fermentation using agricultural residues. *Environ Technol*. 2013;34:139–47.
- Sen SK, Raut S, Bandyopadhyay P, Raut S. Fungal decoloration and degradation of azo dyes: A review. *Fungal Biol Rev*. 2016;30:112–33.
- Sharma A, Shrivastava B, Kuhad RC. Reduced toxicity of Malachite Green decolorized by laccase produced from *Ganoderma* sp. rckk-02 under solid-state fermentation. *3 Biotech*. 2015;5:621–31.
- Somogyi MJ. Notes on sugar determination. *J Biol Chem*. 1952;195:19–23.
- Spina F, Romagnolo A, Prigione V, Tigini V, Varese GC. A scaling-up issue: the optimal bioreactor configuration for effective

- fungal treatment of textile wastewaters. *Chem Eng Trans.* 2014;38:37–42.
34. Wang F, Xu L, Zhao L, Ding Z, Ma H, Terry N. Fungal laccase production from lignocellulosic agricultural wastes by solid-state fermentation: A review. *Microorganisms.* V 7. 2019:665.
 35. Yan J, Niu J, Chen D, Chen Y, Irbis C. Screening of *Trametes* strains for efficient decolorization of Malachite Green at high temperatures and ionic concentrations. *Int Biodeterior Biodegradation.* 2014;87:109–15.
 36. Yang J, Li W, Ng TB, Deng X, Lin J, Ye X. Laccases: production, expression regulation, and applications in pharmaceutical biodegradation. *Front Microbiol.* 2017;8:832.
 37. Yesilada O, Birhanli E, Geckil H. Bioremediation and decolorization of textile dyes by white rot fungi and laccase enzymes. In: Prasad R, editor. *Mycoremediation and Environmental Sustainability.* Fungal Biology. Cham. Springer; 2018. p. 121–53.