

# Re-treatment of previous non-responders and relapsers to interferon plus ribavirin with peginterferon alfa-2a (40KD), ribavirin ± amantadine in patients with chronic hepatitis C: randomized multicentre clinical trial

Mario G. Pessôa,\* Hugo Cheinquer,<sup>†</sup>  
Paulo R.L. Almeida,<sup>‡</sup> Giovanni F. Silva,<sup>§</sup> Maria Patelli J.S. Lima,<sup>||</sup> Raymundo Paraná,<sup>\*\*</sup>  
Marco A. Lacerda,<sup>††</sup> Edison R. Parise,<sup>‡‡</sup> José R.B. Pernambuco,<sup>§§</sup> Suelene S. Pedrosa,<sup>¶¶</sup>  
Rosângela Teixeira,<sup>\*\*\*</sup> Hoel Sette Jr,<sup>†††</sup> Fernando Tatsch<sup>†††</sup>

\* University of São Paulo School of Medicine and Instituto de Infectologia Emílio Ribas, São Paulo, Brazil.

<sup>†</sup> Federal University of Rio Grande do Sul, Porto Alegre, Brazil. <sup>‡</sup> Federal University of Health Sciences of Porto Alegre, Porto Alegre, Brazil.

<sup>§</sup> State University of Botucatu, Botucatu, Brazil. <sup>||</sup> PUC Campinas, Campinas, Brazil. <sup>\*\*</sup> Federal University of Bahia, Salvador, Brazil.

<sup>††</sup> Indiana University, Indiana, USA. <sup>‡‡</sup> Federal University of São Paulo, São Paulo, Brazil. <sup>§§</sup> Federal University of Pernambuco, Recife, Brazil.

<sup>¶¶</sup> Santa Casa de Misericórdia de Goiânia, Goiânia, Brazil. <sup>\*\*\*</sup> Federal University of Minas Gerais, Belo Horizonte, Brazil.

<sup>†††</sup> Hospital Alemão Oswaldo Cruz, São Paulo, Brazil. <sup>†††</sup> Roche Produtos Químicos e Farmacêuticos, São Paulo, Brazil.

## ABSTRACT

**Introduction.** A large number of patients with chronic hepatitis C have not been cured with interferon-based therapy. Therefore, we evaluated the efficacy of amantadine combined with the standard of care (pegylated interferon plus ribavirin) in patients who had not responded to or had relapsed after  $\geq 24$  weeks of treatment with conventional interferon plus ribavirin. **Material and methods.** Patients stratified by previous response (i.e., non-response or relapse) were randomized to 48 weeks of open-label treatment with peginterferon alfa-2a (40KD) 180  $\mu\text{g}/\text{week}$  plus ribavirin 1,000/1,200 mg/day plus amantadine 200 mg/day (triple therapy), or the standard of care (peginterferon alfa-2a [40KD] plus ribavirin). **Results.** The primary outcome was sustained virological response (SVR), defined as undetectable hepatitis C virus RNA in serum ( $< 50$  IU/mL) at end of follow-up (week 72). Among patients with a previous non-response, 12/53 (22.6%; 95% confidence interval [CI] 12.3-36.2%) randomized to triple therapy achieved an SVR compared with 16/52 (30.8%; 95% CI 18.7-45.1%) randomized to the standard of care. Among patients with a previous relapse 22/39 (56.4%; 95% CI 39.6-72.2%) randomized to triple therapy achieved an SVR compared with 23/38 (60.5%; 95% CI 43.4-76.0%) randomized to the standard of care. Undetectable HCV RNA ( $< 50$  IU/mL) at week 12 had a high positive predictive value for SVR. A substantial proportion of non-responders and relapsers to conventional interferon plus ribavirin achieve an SVR when re-treated with peginterferon alfa-2a (40KD) plus ribavirin. **Conclusion.** Amantadine does not enhance SVR rates in previously treated patients with chronic hepatitis C and cannot be recommended in this setting.

**Key words.** Hepatitis C. Re-treatment. Peginterferon alfa-2a (40KD). Amantadine.

## INTRODUCTION

More than 170 million people are infected with hepatitis C virus (HCV) worldwide<sup>1</sup> and are at risk of

the long-term complications of chronic hepatitis C (CHC), which include cirrhosis, liver failure and hepatocellular carcinoma.<sup>2</sup>

It is possible to eradicate HCV by treating patients with the combination of pegylated interferon and ribavirin.<sup>3-6</sup> Eradication of HCV with combination therapy is indicated by the achievement of a sustained virological response (SVR), which is durable<sup>7</sup> and is associated with regression of hepatic fibrosis and a reduction in the incidence of the long-term complications of CHC.<sup>8-13</sup>

Correspondence and reprint request: M. G. Pessôa  
University of São Paulo School of Medicine  
Av. Dr. Eneas de Carvalho Aguiar 255, 9º andar, sala 9117  
São Paulo, SP, Brazil 05403-000  
Tel.: (+55 11) 3067-4240, 3284-3168. Fax: (+55 11) 3287-1631  
E-mail: mgpessoa@usp.br

Manuscript received: May 09, 2011.  
Manuscript accepted: September 19, 2011.

Many patients have obtained lasting benefit from treatment for CHC; however, there is a large and growing number of patients who have either not responded to treatment or who have experienced a virological relapse after completion of treatment. The distinction between non-response and relapse is subtle but important. Non-response is defined as detectable HCV RNA throughout treatment and follow-up. Relapse is defined as suppression of the serum HCV RNA level to below the limit of detection of a sensitive assay at the end of treatment, with subsequent reversion to an HCV RNA-positive state during follow-up (i.e., within 6 months of the end of treatment). Recent studies suggest that response and non-response to interferon may have a genetic basis.<sup>14-17</sup>

The pool of non-responders and relapsers is a heterogeneous group that includes many patients who were previously treated with conventional interferon with or without ribavirin. Such conventional interferon-based treatment regimens are significantly less effective than the current standard of care (pegylated interferon plus ribavirin) and are no longer recommended.<sup>3,18</sup>

Amantadine is an oral antiviral agent that has been shown to improve the efficacy of conventional interferon plus ribavirin in patients who have not responded to conventional interferon monotherapy.<sup>19</sup> However, the impact of amantadine on virological response rates of interferon-based treatment is controversial, and a recent large multicentre study of 700 previously untreated patients with chronic HCV genotype 1 infection did not demonstrate an improvement on the virological response of peginterferon alfa-2a (40KD) and ribavirin when compared with placebo.<sup>20</sup>

Despite the failure to show any benefit of amantadine in previously untreated patients, the impact of amantadine on the efficacy of peginterferon and ribavirin in patients with previous treatment failure is largely unknown. Therefore, the objective of this study was to compare the efficacy of the standard of care –the combination of peginterferon alfa-2a (40KD) plus ribavirin– with that of a triple-therapy regimen comprising peginterferon alfa-2a (40KD), ribavirin and amantadine in patients who either did not respond to or relapsed after at least 24 weeks of treatment with the combination of conventional interferon plus ribavirin.

## MATERIALS AND METHODS

### Patients

Adults with a positive anti-HCV antibody test, detectable HCV RNA in serum, elevated alanine ami-

notransferase (ALT) serum levels on at least two occasions during the previous 6 months and a liver biopsy result within the previous 36 months consistent with the diagnosis of CHC were eligible for the trial. Patients with hepatic cirrhosis could be enrolled provided that they had compensated liver disease, defined as Child-Pugh class A disease.

Eligible patients had received at least 24 weeks of previous treatment with conventional interferon alfa plus ribavirin, the outcome of which was either virological non-response or virological relapse. The previous course of treatment must have been completed at least 12 weeks prior to enrolment in the present study.

Virological non-response was defined as detectable HCV RNA in serum at the end of previous treatment with conventional interferon alfa plus ribavirin. Virological relapse was defined as undetectable HCV RNA in serum at the end of previous treatment and detectable HCV RNA in serum at the end of a 24-week follow-up period.

Patients infected with hepatitis A or B virus or human immunodeficiency virus were excluded, as were patients with a neutrophil count < 1,500 cells/mm<sup>3</sup>, serum creatinine level > 1.5 times the upper limit of normal, or haemoglobin level < 12 g/dL (women) or < 13 g/dL (men). Patients with serious chronic diseases including severe psychiatric disease or alcohol or drug abuse within 1 year were ineligible. Pregnant or breastfeeding women and male partners of pregnant women were excluded. All eligible patients were required to use two forms of effective contraception during treatment and for 6 months after the end of treatment.

All patients provided written informed consent before enrolling in the trial. The trial was conducted in accord with the Declaration of Helsinki, the laws and regulations of Brazil, and Guidelines for Good Clinical Practice.

### Treatment

Patients were randomized to 48 weeks of open-label treatment with subcutaneous peginterferon alfa-2a (40KD) (PEGASYS®, Roche, Basel, Switzerland) 180 µg/week plus oral ribavirin (COPEGUS®, Roche, Basel, Switzerland) 1,000 mg/day (body weight ≤ 75 kg) or 1,200 mg/day (body weight > 75 kg) plus oral amantadine 200 mg/day, or the standard of care (peginterferon alfa-2a [40KD] plus ribavirin combination therapy). The daily dosages of ribavirin and amantadine were administered in two divided doses.

Patients were stratified by previous treatment response (i.e., previous non-response or previous relapse); thus, there were four treatment groups as depicted in Figure 1.

In the event of adverse events or laboratory abnormalities the dosage of peginterferon alfa-2a (40KD) could be reduced in steps to 135, 90 and 45  $\mu\text{g}/\text{week}$ .

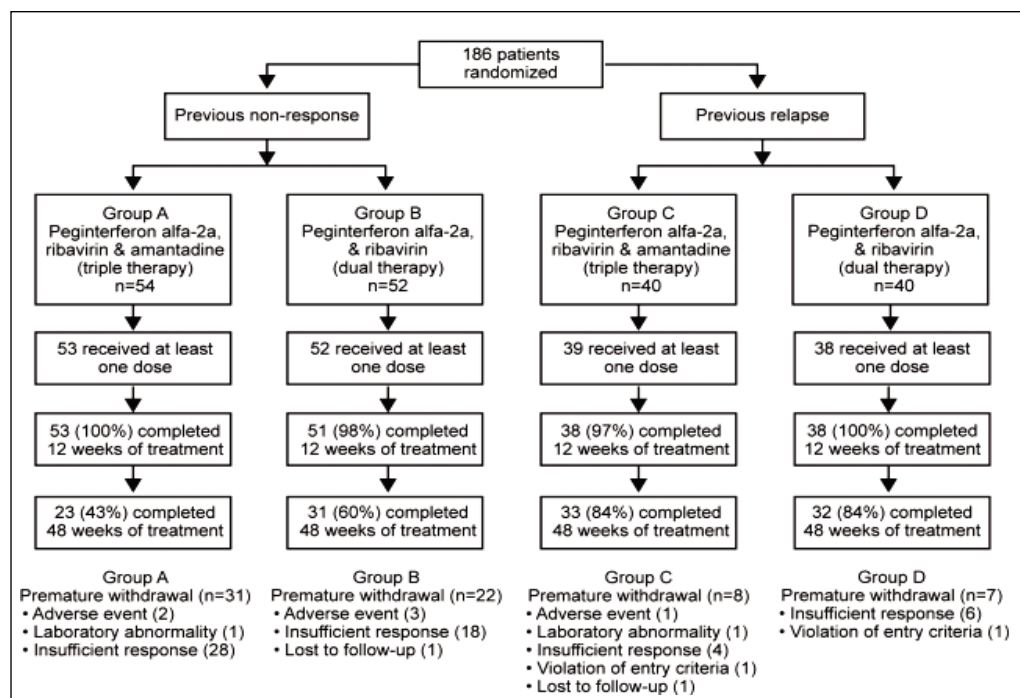

Figure 1. Flow of patients through the trial.

Table 1. Patient characteristics at baseline.

Characteristic	Previous non-response		Previous relapse	
	Group A (n = 53)	Group B (n = 52)	Group C (n = 39)	Group D (n = 38)
Male, n (%)	38 (71.7)	40 (76.9)	24 (61.5)	28 (73.7)
Mean age, years $\pm$ SD	50.2 $\pm$ 9.9	47.2 $\pm$ 9.4	51.5 $\pm$ 10.0	48.7 $\pm$ 8.5
Mean weight, kg $\pm$ SD	76.3 $\pm$ 14.3	77.7 $\pm$ 14.1	75.4 $\pm$ 13.2	81.6 $\pm$ 12.9
Race, n (%)				
White	45 (84.9)	44 (84.6)	37 (94.9)	34 (89.5)
Black	1 (1.9)	3 (5.8)	0	0
Other	7 (13.2)	5 (9.6)	2 (5.1)	4 (10.5)
ALT quotient, * n (%)				
$\leq$ 3	40 (75.5)	33 (63.5)	29 (76.3)	28 (77.8)
$>$ 3	13 (24.5)	19 (36.5)	9 (23.7)	8 (22.2)
Cirrhosis (fibrosis stage F4), n (%)	8 (15.1)	6 (11.5)	12 (30.8)	10 (26.3)
Baseline HCV RNA level $\geq$ 800,000 IU/mL, n (%)	32 (60.4)	28 (54.9)	22 (56.4)	24 (63.2)
HCV genotype, n (%)				
1	40 (75.5)	30 (57.7)	10 (25.6)	15 (39.5)
2	0	1 (1.9)	2 (5.1)	3 (7.9)
3	13 (24.5)	19 (36.5)	27 (69.2)	20 (52.6)
Genotype not reported	0	2 (3.9)	0	0

ALT: alanine aminotransferase. HCV: hepatitis C virus. SD: standard deviation. \*ALT quotient is defined as the patient's ALT value divided by the upper limit of normal.

The dosage of ribavirin was reduced to 600 mg/day in the event of a reduction in haemoglobin level to < 10 g/dL in patients without cardiovascular disease, or a reduction of > 2 g/dL over any 4-week period in a patient with stable cardiovascular disease. Ribavirin was discontinued in the event of a reduction in haemoglobin level to < 8.5 g/dL in patients without cardiovascular disease or a persistent haemoglobin level < 12 g/dL after 4 weeks of therapy at the reduced dosage (600 mg/day) in patients with stable cardiovascular disease. Use of erythropoietin-stimulating agents for the treatment of anaemia was allowed at the discretion of the investigator.

Monotherapy with peginterferon alfa-2a (40KD) was permitted if ribavirin was discontinued. At the discretion of the investigator peginterferon alfa-2a (40KD) or ribavirin could be restarted and/or the dosage increased after resolution of the precipitating event. Amantadine was administered at a reduced dosage (100 mg/day) in patients with renal impairment and those aged > 65 years. Patients with detectable HCV RNA in serum at week 24 of treatment were withdrawn from the study.

### Outcomes

Serum HCV RNA was measured by qualitative polymerase chain reaction (PCR) assay (Cobas AmpliCor HCV Test v2.0, Roche, Basel, Switzerland; limit of detection 50 IU/mL) at baseline and at weeks 12, 24 and 48 of treatment and at the end of follow-up (week 72). A quantitative HCV RNA test (Cobas AmpliCor HCV Monitor v2.0, Roche, Basel, Switzerland; limit of quantitation 600 IU/mL) was performed on serum samples with detectable HCV RNA.

The primary efficacy outcome in the study was SVR, defined as undetectable HCV RNA (< 50 IU/mL) at the end of follow-up (week 72). Secondary efficacy outcomes included sustained biochemical response defined as normalization of serum ALT levels at the end of follow-up (week 72), early virological response (EVR) at week 12 (defined as undetectable HCV RNA by qualitative PCR assay [ $< 50$  IU/mL] or  $\geq 2\text{-log}_{10}$  drop in serum HCV RNA by quantitative PCR), complete early virological response (cEVR) at week 12 (defined as undetectable HCV RNA by qualitative PCR assay [ $< 50$  IU/mL]) and safety as assessed by means of adverse events and laboratory abnormalities.

### Statistical methods

At the time the study was planned, it was known that re-treating non-responders or relapsers to in-

terferon and ribavirin with the same therapeutic regimen yielded low virological responses. The authors considered that offering the same regimen when re-treating would produce an SVR similar to interferon monotherapy in naive patients.<sup>21</sup> Therefore, an SVR rate of 5% or less, which is similar to interferon monotherapy in naive patients, was considered the null hypothesis. The alternative hypothesis is an SVR  $\geq 5\%$  with the combination of amantadine plus the standard of care. The alternative hypothesis was anticipated to be approximately 20% (vs.  $\leq 5\%$  with the standard of care).<sup>22</sup> At a 5% significance level a sample size of 30 patients per treatment group would be required to provide 80% statistical power to reject the null hypothesis. A minimum of 120 patients would then be required to be randomized in a 1:1 ratio to amantadine plus the standard of care (groups A, C) or the standard of care alone (groups B, D) to detect a significant difference if the SVR rate was at least 20%. To provide for protocol violations and withdrawal of patients the target sample sizes for groups A, B, C and D, respectively, were 50, 50, 40 and 40 patients.

The efficacy analysis was conducted according to the intention-to-treat principle. All eligible patients who received one dose of study medication were included; individuals without end of follow-up HCV RNA determinations were considered not to have had an SVR. SVR rates between groups A and B (non-responders) and groups C and D (relapsers) were compared by Cochran-Mantel-Haenszel test stratified by study centre. The safety population included all patients who received one dose of study medication and who had at least one post-baseline safety assessment.

Multiple logistic regression analysis was performed to examine the prognostic value of baseline characteristics for SVR. Characteristics considered for inclusion were previous treatment outcome (non-response vs. relapse), randomization to amantadine, sex, race (white vs. non-white), age ( $\leq 40$  years vs.  $> 40$  years), weight ( $\leq 75$  kg vs.  $> 75$  kg), HCV genotype (1 vs. 2 or 3), presence of cirrhosis (fibrosis stage F4 vs.  $< F4$ ), HCV RNA level ( $\leq 800,000$  IU/mL vs.  $> 800,000$  IU/mL) and ALT quotient ( $\leq 3$  vs.  $> 3$ ).

## RESULTS

The first patient was enrolled in June 2003 and the last patient completed follow-up in November 2005. A total of 186 patients were randomized (106 non-responders and 80 relapsers) (Figure 1). Two patients did not receive study medication and two patients were

HCV RNA negative at baseline; thus, the intention-to-treat population comprised 182 individuals.

Baseline characteristics of patients are presented in Table 1. The population was predominantly male, of white race, with a mean age of approximately 50 years and a baseline HCV RNA level  $\geq 800,000$  IU/mL. The majority of patients with a previous non-response were infected with HCV genotype 1 (75.5% in group A and 57.7% in group B), whereas the majority of patients with a previous relapse were infected with HCV genotype 3 (69.2% in group C and 52.6% in group D). Reasons for premature discontinuation are presented in Figure 1.

## Efficacy

- Patients with previous non-response.** There was no statistically significant difference between groups A and B in the virological response at the end of treatment or follow-up or in the biochemical response rate at the end of follow-up (Figure 2). Among patients with a previous non-response the rate of SVR at the end of follow-up was 22.6% (95% confidence interval [CI] 12.3-36.2%) in group A and 30.8% (95% CI 18.7-45.1%) in group B. There was no statistically significant difference between groups A and B in the percentage of patients

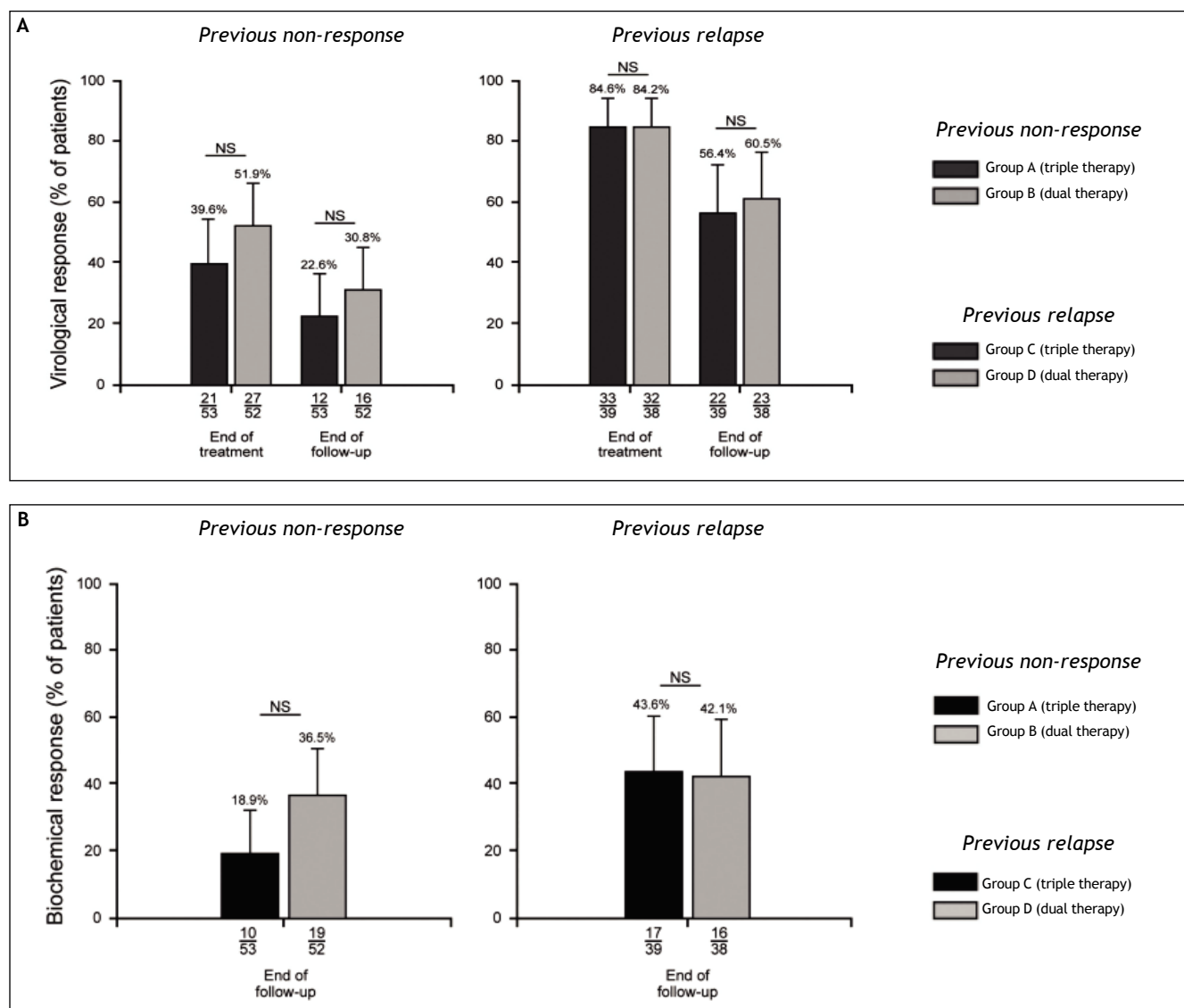

**Figure 2.** A. Virological response at end of follow-up and end of treatment. B. Biochemical response at end of follow-up. NS: not significant.

with an EVR at week 12 (group A: 41/53, 77.4%, 95% CI 63.8-87.7%; group B: 38/52, 73.1%, 95% CI 59.0-84.4%) or in the percentage of patients with a cEVR (group A: 18/53, 34.0%, 95% CI 21.5-48.3%; group B: 19/52, 36.5%, 95% CI 23.6-51.0%).

- **Patients with previous relapse.** There was no significant difference between groups C and D in the virological response at the end of treatment or follow-up or in the biochemical response rate at the end of follow-up (Figure 2A). Among patients with a previous relapse the rate of SVR at the end of follow-up was 56.4% (95% CI 39.6-72.2%) in group C and 60.5% (95% CI 43.4-76.0%) in group D.

There was no statistically significant difference between groups C and D in the percentage of patients with an EVR at week 12 (group C: 36/39, 92.3%, 95% CI 79.1-98.4%; group D 35/38, 92.1%, 95% CI 78.6-98.3%) or in the percentage of patients with a cEVR (group C: 30/39, 76.9%, 95% CI 60.7-88.9%; group D: 31/38, 81.6%, 95% CI 65.7-92.3%).

- **Patients with previous non-response or relapse combined.** In a *post hoc* analysis patients

with either a previous non-response or relapse were combined and the rates SVR compared for triple and dual therapy. This analysis confirmed the protocol specified analyses by demonstrating that patients with either a previous non-response or relapse had a lower rate of SVR if they were randomized to triple therapy (37.0%; groups A and C combined) compared to those randomized to dual therapy (43.3%; groups B and D combined).

### Predictors of SVR

The predictive utility of an EVR and cEVR at week 12 for SVR at the end of follow-up is depicted in Figure 3. No patient with a previous non-response achieved an SVR in the absence of an EVR (Figure 3A). Most patients with a previous relapse had an EVR at week 12, and the majority of these individuals (61%) achieved an SVR (Figure 3B). Among previous non-responders, the positive predictive value of a cEVR for SVR was 70% (Figure 3C), which is considerably higher than that for an EVR (35%) (Figure 3A). The positive predictive value of cEVR was similar in previous relapsers

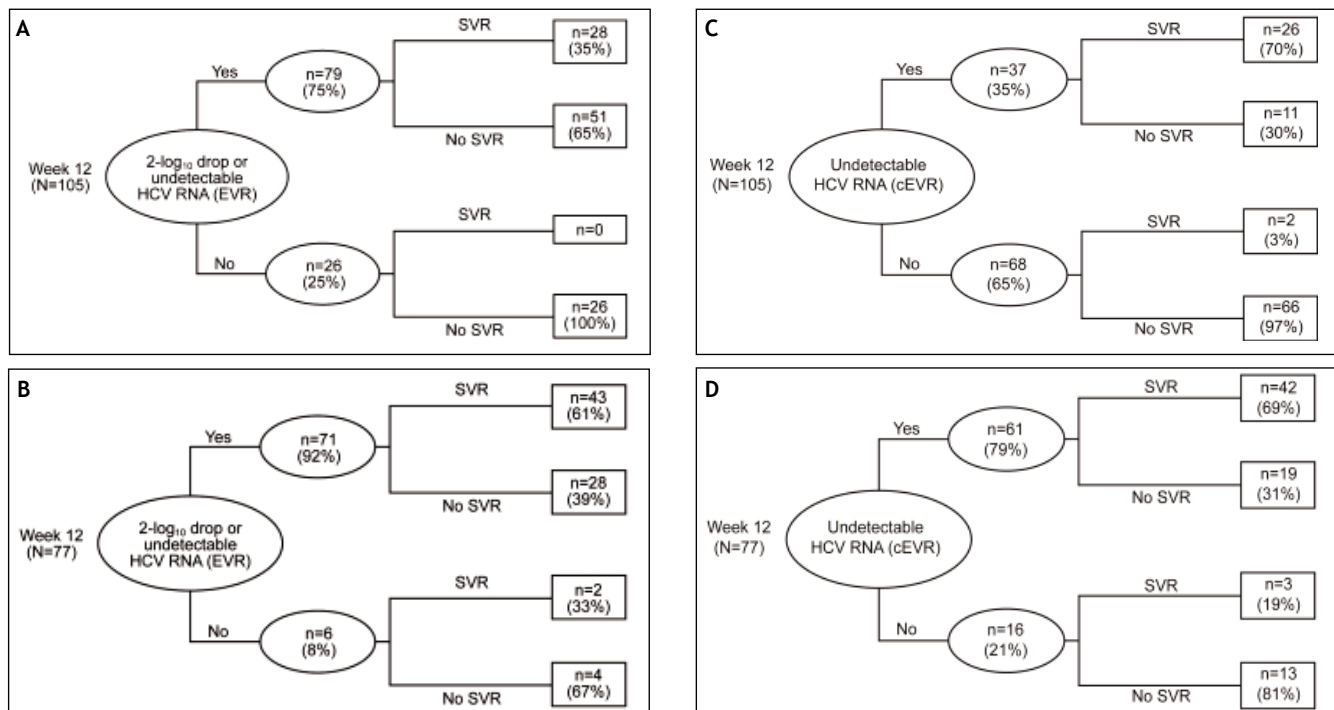

**Figure 3.** Virological response at week 12 as a predictor of sustained virological response (SVR). A. Early virological response (EVR) as a predictor of SVR in patients with a previous non-response (groups A and B). B. EVR as a predictor of SVR in patients with a previous relapse (groups C and D). C. Complete EVR (cEVR) as a predictor of SVR in patients with a previous non-response (groups A and B). D. cEVR as a predictor of SVR in patients with a previous relapse (groups C and D).

(69%) (Figure 3D); however the difference between this value and that of an EVR (61%) (Figure 3B) was not as great.

Significant baseline predictors of SVR retained in the final multiple logistic regression model included previous relapse (odds ratio [OR] 4.07 vs. previous non-response, 95% CI 2.02-8.27,  $p < 0.0001$ ) and infection with HCV genotype 2 or 3 (OR 2.30 vs. genotype 1, 95% CI 1.11-4.75,  $p = 0.024$ ).

### Safety and tolerability

The safety population comprised 184 patients, six of whom withdrew from treatment because of adverse events (Figure 1). The most common adverse events included leucopenia, neutropenia, thrombocytopenia, fatigue and anaemia (Table 2). A total of 14 serious adverse events were reported in 10 patients in the trial. One patient in group A died during treatment from cardiogenic shock, which was related to treatment in the opinion of the investigator. The frequency of dose modifications is presented in Table 3. Most dosage adjustments of peginterferon alfa-2a (40KD) and of ribavirin were made in response to laboratory abnormalities rather than adverse events. Amantadine dosage adjustments were infrequent and most of these were for adverse events.

## DISCUSSION

The results of this analysis show that HCV can be eradicated with peginterferon alfa-2a (40KD) plus ribavirin in a substantial proportion of patients who have either not had a virological response during previous therapy or have experienced a virological relapse after completion of therapy with conventional interferon plus ribavirin.

The primary results of the study confirm that amantadine does not augment the efficacy of peginterferon alfa-2a (40KD) plus ribavirin in patients who have not responded to treatment with conventional interferon plus ribavirin, and extend this finding to include patients with a previous relapse. We were unable to confirm the preliminary findings of Brillanti, *et al.*<sup>22</sup> that suggested that amantadine enhances the efficacy of interferon plus ribavirin in interferon non-responders. As other authors have also been unable to demonstrate any benefit of amantadine in combination with pegylated interferon plus ribavirin, the use of triple therapy with amantadine should be discouraged.

A previous study in Brazil showed that the combination of peginterferon alfa-2a (40KD) plus ribavirin produced an SVR in 51% of relapsers and 26% of non-responders to conventional interferon plus ribavirin.<sup>23</sup> The results of the present study are consis-

Table 2. Adverse events.

	Previous non-response		Previous relapse	
	Group A (n = 53)	Group B (n = 52)	Group C (n = 40)	Group D (n = 39)
Patients with $\geq 1$ serious adverse event, n (%)	3 (5.7)	3 (5.8)	3 (7.5)	1 (2.6)
Total number of serious adverse events, n	4	6	3	1
Incidence of specific adverse events,* n (%)				
Leucopenia	25 (47.2)	25 (48.1)	24 (60.0)	27 (69.2)
Neutropenia	19 (35.8)	27 (51.9)	21 (52.5)	22 (56.4)
Thrombocytopenia	17 (32.1)	18 (34.6)	22 (55.0)	19 (48.7)
Fatigue	14 (26.4)	21 (40.4)	14 (35.0)	18 (46.2)
Anaemia	19 (35.8)	14 (26.9)	17 (42.5)	14 (35.9)
Myalgia	12 (22.6)	9 (17.3)	8 (20.0)	16 (41.0)
Insomnia	21 (39.6)	12 (23.1)	11 (27.5)	6 (15.4)
Headache	18 (34.0)	18 (34.6)	14 (35.0)	14 (35.9)
Irritability	7 (13.2)	12 (23.1)	7 (17.5)	11 (28.2)
Lymphopenia	10 (18.9)	7 (13.5)	11 (27.5)	9 (23.1)
Pruritus	7 (13.2)	10 (19.2)	10 (25.0)	7 (17.9)
Nausea	6 (11.3)	9 (17.3)	10 (25.0)	7 (17.9)
Depression	12 (22.6)	9 (17.3)	4 (10.0)	7 (17.9)
Anorexia	11 (20.8)	7 (13.5)	8 (20.0)	4 (10.3)
Pyrexia	5 (9.4)	9 (17.3)	4 (10.0)	8 (20.5)
Dizziness	1 (1.9)	6 (11.5)	8 (20.0)	3 (7.7)

\*Adverse events that occurred in at least 20% of patients in at least one treatment group.

**Table 3.** Dosage modifications for adverse events, laboratory abnormalities or other reasons.

	Previous non-response		Previous relapse	
	Group A (n = 53)	Group B (n = 52)	Group C (n = 40)	Group D (n = 39)
Peginterferon alfa-2a (40KD) dosage modifications, n (%)				
Adverse events	2 (4)	2 (4)	2 (5)	3 (8)
Laboratory abnormalities	10 (19)	13 (25)	11 (28)	12 (31)
Other (not specified)	0	0	0	1 (3)
Ribavirin dosage modifications, n (%)				
Adverse events	0	4 (8)	0	1 (3)
Laboratory abnormalities	9 (17)	7 (13)	6 (15)	5 (13)
Weight change	2 (4)	1 (2)	0	2 (5)
Other (not specified)	1 (2)	1 (2)	1 (3)	0
Amantadine dosage modifications, n (%)				
Adverse events	4 (8)	N/A	2 (5)	NA
Laboratory abnormalities	2 (4)	N/A	0	NA
Age ≥ 65 years	1 (2)	N/A	0	NA
Other (not specified)	1 (2)	N/A	0	NA

N/A: not applicable.

tent with those of the earlier study and, taken together, provide a clear indication of the prognosis of patients for whom physicians are contemplating re-treatment.

The definition of previous response is a strength of this study. Only patients who had received at least 24 weeks of therapy were eligible, and strict criteria were applied to ensure that patients with a non-response and those with a relapse were treated separately in the analysis. These criteria are reflected by differences in the baseline characteristics of patients with non-response vs. relapse. A higher proportion of non-responders were infected with HCV genotype 1 and a higher proportion of relapsers were infected with HCV genotype 2 or 3. Moreover, a higher proportion of relapsers had a histological diagnosis of cirrhosis or bridging fibrosis. Advanced fibrosis is a well-established poor prognostic factor in patients with CHC.

The results demonstrate the importance of the previous response to the standard of care as a predictor of SVR. Patients with a previous virological relapse after completion of conventional combination therapy had considerably higher SVR rates than patients who had not had a virological response during previous treatment. This finding shows that physicians should carefully document the nature of a first response to therapy and should not hesitate to re-treat patients with a previous relapse.

Our study confirms that cEVR is a useful parameter in the management of patients who have not res-

ponded to a previous course of conventional interferon-based therapies. cEVR had a higher positive predictive value for SVR among both non-responders and relapsers to previous treatment. A recent analysis of data from a large, randomized, international study showed that complete viral suppression at week 12 (HCV RNA < 50 IU/mL) of treatment with peginterferon alfa-2a (40KD) plus ribavirin was a strong predictor of SVR in non-responders to previous treatment with pegylated interferon alfa-2b (12KD) plus ribavirin. The positive predictive value of week 12 HCV RNA ≤ 50 UI/mL was 57% in that study.<sup>24</sup> In our study the positive predictive value was 70%.

Our analysis identified several unexpected associations between baseline factors and SVR. Among previous relapsers the SVR rate was considerably higher in those with low baseline ALT quotients (70.2% vs. 29.4% in those with ALT quotients ≤ 3 and > 3, respectively). Even more surprising was the SVR rates of 63.0% in patients with a high baseline HCV RNA level and 51.6% in those with a low baseline HCV RNA level. These findings are likely to be the result of confounding because of the low number of patients in some subgroups.

There are now sufficient data to demonstrate that patients who have not achieved an SVR after previous treatment benefit from re-treatment with the standard of care. SVR rates in patients who have not responded to previous treatment with conventional interferon-based therapy have generally been reported to be in the order of 20% after re-treatment



with pegylated interferon plus ribavirin.<sup>25-30</sup> Consistent with the results of the present study, other authors have reported considerably higher SVR rates (in the order of 40-55%) in patients with a previous relapse to conventional interferon-based therapy.<sup>26-29</sup> The somewhat higher SVR rates in patients with prior relapse in our study may be attributable to the use of a ribavirin dose of 1,000 or 1,200 mg/day. In previous studies either or both of the doses of peginterferon or ribavirin have been lower than what is currently recommended.<sup>26,27,29</sup> Most of the patients included in this study had received a biosimilar conventional interferon of which little is known of the comparative efficacy. Thus, one might hypothesise that the higher response rates in our study was a reflection of lower efficacy of the biosimilar used in the previous course of treatment leading to a higher proportion of unexpected relapsers. The SVR rate of 26% in previous non-responders infected with HCV genotype 1 is particularly noteworthy. Other studies of re-treatment with pegylated interferon-based therapy have reported lower SVR rates in this important subgroup. For example, 17% of genotype 1 non-responders to interferon alfa-2b plus ribavirin achieved an SVR after re-treatment with pegylated interferon alfa-2b (12KD) plus ribavirin 800-1,400 mg/day.<sup>28</sup>

Re-treatment with peginterferon alfa-2a (40KD) plus ribavirin results in an SVR in a proportion of patients who have not responded to a previous 12-week course of pegylated interferon alfa-2b (12KD) plus ribavirin<sup>24</sup> or who have relapsed after a first course of peginterferon alfa-2a (40KD) plus ribavirin.<sup>31</sup> In the case of non-responders to previous treatment with pegylated interferon alfa-2b (12KD) plus ribavirin, extending the duration of re-treatment with peginterferon alfa-2a (40KD) plus ribavirin to 72 weeks results in an SVR rate of 16%.<sup>24</sup>

## CONCLUSION

A substantial proportion of patients who have not responded to or have relapsed after treatment with conventional interferon plus ribavirin achieve an SVR when re-treated with peginterferon alfa-2a (40KD) plus ribavirin. Amantadine does not enhance SVR rates and cannot be recommended in this setting.

## ABBREVIATIONS

- **SVR:** sustained virological response.
- **HCV:** hepatitis C virus.
- **CHC:** chronic hepatitis C.

- **ALT:** alanine aminotransferase.
- **EVR:** early virological response.
- **OR:** odds ratio.
- **SD:** standard deviation.

## GRANTS AND OTHER FINANCIAL SUPPORT

This study was funded by Roche Produtos Químicos e Farmacêuticos.

## REFERENCES

1. Shepard CW, Finelli L, Alter MJ. Global epidemiology of hepatitis C virus infection. *Lancet Infect Dis* 2005; 5: 558-67.
2. Perz JF, Armstrong GL, Farrington LA, Hutin YJ, Bell BP. The contributions of hepatitis B virus and hepatitis C virus infections to cirrhosis and primary liver cancer worldwide. *J Hepatol* 2006; 45: 529-38.
3. Dienstag JL, McHutchison JG. American Gastroenterological Association technical review on the management of hepatitis C. *Gastroenterology* 2006; 130: 231-64.
4. Manns MP, McHutchison JG, Gordon SC, Rustgi VK, Shiffman M, Reindollar R, Goodman ZD, et al. Peginterferon alfa-2b plus ribavirin compared with interferon alfa-2b plus ribavirin for initial treatment of chronic hepatitis C: a randomised trial. *Lancet* 2001; 358: 958-65.
5. Fried MW, Shiffman ML, Reddy KR, Smith, C, Marinos G, Gonçales FL Jr, Häussinger D, et al. Peginterferon alfa-2a plus ribavirin for chronic hepatitis C virus infection. *N Engl J Med* 2002; 347: 975-82.
6. Hadziyannis SJ, Sette H Jr., Morgan TR, Balan V, Diago M, Marcellin P, Ramadori G, et al. Peginterferon-alpha2a and ribavirin combination therapy in chronic hepatitis C: a randomized study of treatment duration and ribavirin dose. *Ann Intern Med* 2004; 140: 346-55.
7. Swain MG, Lai MY, Shiffman ML, Cooksley WG, Zeuzem S, Dieterich DT, Abergel A, et al. A sustained virologic response is durable in patients with chronic hepatitis C treated with peginterferon alfa-2a and ribavirin. *Gastroenterology* 2010; 139(5): 1593-601.
8. Marcellin P, Boyer N, Gervais A, Martinot M, Pouteau M, Castelnau C, Kilani A, et al. Long-term histologic improvement and loss of detectable intrahepatic HCV RNA in patients with chronic hepatitis C and sustained response to interferon-alpha therapy. *Ann Intern Med* 1997; 127: 875-81.
9. Camma C, Di Bona D, Schepis F, Heathcote J, Zeuzem S, Pockros PJ, Marcellin P, et al. Effect of peginterferon alfa-2a on liver histology in chronic hepatitis C: a meta-analysis of individual patient data. *Hepatology* 2004; 39: 333-42.
10. Kasahara A, Tanaka H, Okanoue T, Imai Y, Tsubouchi H, Yoshioka K, Kawata S, et al. Interferon treatment improves survival in chronic hepatitis C patients showing biochemical as well as virological responses by preventing liver-related death. *J Viral Hepat* 2004; 11: 148-56.
11. Veldt BJ, Saracco G, Boyer N, Cammà C, Bellobuono A, Hopf U, Castillo I, et al. Long term clinical outcome of chronic hepatitis C patients with sustained virological response to interferon monotherapy. *Gut* 2004; 53: 1504-8.
12. Hung CH, Lee CM, Lu SN, Wang JH, Hu TH, Tung HD, Chen CH, et al. Long-term effect of interferon alpha-2b plus ribavirin therapy on incidence of hepatocellular carcinoma

- in patients with hepatitis C virus-related cirrhosis. *J Viral Hepat* 2006; 13: 409-14.
13. Veldt BJ, Heathcote EJ, Wedemeyer H, Reichen J, Hofmann WP, Zeuzem S, Manns MP, et al. Sustained virologic response and clinical outcomes in patients with chronic hepatitis C and advanced fibrosis. *Ann Intern Med* 2007; 147: 677-84.
  14. Chen L, Borozan I, Feld J, Sun J, Tannis LL, Coltescu C, Heathcote J, et al. Hepatic gene expression discriminates responders and nonresponders in treatment of chronic hepatitis C viral infection. *Gastroenterology* 2005; 128: 1437-44.
  15. Asselah T, Bieche I, Narguet S, Sabbagh A, Laurendeau I, Ripault MP, Boyer N, et al. Liver gene expression signature to predict response to pegylated interferon plus ribavirin combination therapy in patients with chronic hepatitis C. *Gut* 2008; 57: 516-24.
  16. Selzner N, Chen L, Borozan I, Edwards A, Heathcote EJ, McGilvray I. Hepatic gene expression and prediction of therapy response in chronic hepatitis C patients. *J Hepatol* 2008; 48: 708-13.
  17. Ge D, Fellay J, Thompson AJ, Shianna KV, Urban TJ, Heintzen EL, Qiu P, et al. Genetic variation in IL28B predicts hepatitis C treatment-induced viral clearance. *Nature* 2009; 461: 399-401.
  18. Ghany MG, Strader DB, Thomas DL, Seeff LB. American Association for the Study of Liver Diseases. Diagnosis, management, and treatment of hepatitis C: an update. *Hepatology* 2009; 49: 1335-74.
  19. Deltenre P, Henrion J, Canva V, Dharancy S, Texier F, Louvet A, De Maeght S, et al. Evaluation of amantadine in chronic hepatitis C: a meta-analysis. *J Hepatol* 2004; 41: 462-73.
  20. Von Wagner M, Hofmann WP, Gerlinde T, Berg T, Goeser T, Spengler U, Hinrichsen H, et al. Placebo-controlled trial of 400 amantadine combined with peginterferon alpha-2a and ribavirin for 48 weeks in chronic hepatitis C virus-1 infection. *Hepatology* 2008; 48: 1404-11.
  21. Schalm SW, Brouwer JT, Bekkering FC, van Rossum TG. New treatment strategies in non-responder patients with chronic hepatitis C. *J Hepatol* 1999; 31(Suppl. 1): 184-8.
  22. Brillanti S, Levantesi F, Masi L, Folli M, Bolondi L. Triple antiviral therapy as a new option for patients with interferon nonresponsive chronic hepatitis C. *Hepatology* 2000; 32: 630-4.
  23. Parise E, Cheinquer H, Crespo D, Meirelles A, Martinelli AV, Sette H, Gallizi J, et al. Peginterferon alfa-2a (40KD) (PEGASYS) plus ribavirin (COPEGUS) in retreatment of chronic hepatitis C patients, nonresponders and relapsers to previous conventional interferon plus ribavirin therapy. *Braz J Infect Dis* 2006; 10: 11-6.
  24. Jensen DM, Marcellin P, Freilich B, Andreone P, Di Bisceglie A, Brandão-Mello CE, Reddy KR, et al. Re-treatment of patients with chronic hepatitis C who do not respond to peginterferon alfa-2b. *Ann Int Med* 2009; 150: 528-40.
  25. Shiffman ML, Di Bisceglie AM, Lindsay KL, Morishima C, Wright EC, Everson GT, Lok AS, et al. Peginterferon alfa-2a and ribavirin in patients with chronic hepatitis C who have failed prior treatment. *Gastroenterology* 2004; 126: 1015-23.
  26. Jacobson IM, Gonzalez SA, Ahmed F, Lebovics E, Min AD, Bodenheimer HC Jr., Esposito SP, et al. A randomized trial of pegylated interferon alpha-2b plus ribavirin in the retreatment of chronic hepatitis C. *Am J Gastroenterol* 2005; 100: 2453-62.
  27. Krawitt EL, Ashikaga T, Gordon SR, Ferrentino N, Ray MA, Lidofsky SD. Peginterferon alfa-2b and ribavirin for treatment-refractory chronic hepatitis C. *J Hepatol* 2005; 43: 243-9.
  28. Poynard T, Colombo M, Bruix J, Schiff E, Terg R, Flamm S, Moreno-Otero R, et al.; Epic Study Group. Peginterferon alfa-2b and ribavirin: effective in patients with hepatitis C who failed interferon alfa/ribavirin therapy. *Gastroenterology* 2009; 136: 1618-28.
  29. Sherman M, Yoshida EM, Deschenes M, Krajden M, Bain VG, Peltekian K, Anderson F, et al. Peginterferon alfa-2a (40KD) plus ribavirin in chronic hepatitis C patients who failed previous interferon therapy. *Gut* 2006; 55: 1631-8.
  30. Taliani G, Gemignani G, Ferrari C, Aceti A, Bartolozzi D, Blanc PL, Capanni M, et al. Pegylated interferon alfa-2b plus ribavirin in the retreatment of interferon-ribavirin nonresponder patients. *Gastroenterology* 2006; 130: 1098-106.
  31. Berg C, Goncales FL Jr., Bernstein DE, Sette H Jr., Rase-nack J, Diago M, Jensen DM, et al. Re-treatment of chronic hepatitis C patients after relapse: efficacy of peginterferon-alpha-2a (40 kDa) and ribavirin. *J Viral Hepat* 2006; 13: 435-40.